

# Kubota

- U.S.A. : **KUBOTA TRACTOR CORPORATION**  
3401 Del Amo Blvd., Torrance, CA 90503, U.S.A.  
Telephone : (310)370-3370  
Western Division : 1175 S. Guild Av., Lodi, CA 95240  
Telephone : (209)334-9910  
Central Division : 14855 FAA Blvd., Fort Worth, TX 76155  
Telephone : (817)571-0900  
Northern Division : 6300 at One Kubota Way, Groveport, OH 43125  
Telephone : (614)835-1100  
Southeast Division : 1025 Northbrook Parkway, Suwanee, GA 30024  
Telephone : (770)995-8855
- Canada : **KUBOTA CANADA LTD.**  
5900 14th Avenue, Markham, Ontario, L3S 4K4, Canada  
Telephone : (905)294-7477
- France : **KUBOTA EUROPE S.A.S**  
19-25, Rue Jules Verceyruysse, Z.I. BP88, 95101 Argenteuil Cedex, France  
Telephone : (33)1-3426-3434
- Italy : **KUBOTA EUROPE S.A.S Italy Branch**  
Via Grandi, 29 20068 Peschiera Borrome (MI) Italy  
Telephone : (39)02-51650377
- Germany : **KUBOTA BAUMASCHINEN GmbH**  
Steinhauser str. 100, 66482 Zweibrucken Rheinlandpfalz Germany  
Telephone : (49)6332-4870100
- U.K. : **KUBOTA (U.K.) LTD.**  
Dormer Road, Thame, Oxfordshire, OX9 3UN, U.K.  
Telephone : (44)1844-214500
- Australia : **KUBOTA TRACTOR AUSTRALIA PTY LTD.**  
25-29 Permas Way, Truganina, VIC 3029, Australia  
Telephone : (61)-3-9394-4400
- Malaysia : **SIME KUBOTA SDN. BHD.**  
No.3 Jalan Sepadu 25/123 Taman Perindustrian Axis,  
Seksyen 25, 40400 Shah Alam, Selangor Darul Ehsan Malaysia  
Telephone : (60)3-736-1388
- Philippines : **KUBOTA PHILIPPINES, INC.**  
232 Quirino Highway, Baesa, Quezon City 1106, Philippines  
Telephone : (63)2-422-3500
- Taiwan : **SHIN TAIWAN AGRICULTURAL MACHINERY CO., LTD.**  
16, Fengping 2nd Rd, Taliiao Shiang Kaohsiung 83107, Taiwan R.O.C.  
Telephone : (886)7-702-2333
- Thailand : **SIAM KUBOTA CORPORATION CO., LTD.**  
101/19-24 Moo 20, Navanakorn Industrial Estate, Tambon Khlongnueng, Amphur Khlongnuang,  
Pathumthani 12120, THAILAND  
Telephone : (66)2-909-0300
- Japan : **KUBOTA Corporation**  
Farm & Industrial Machinery International Operations Headquarters  
2-47, Shikitsuhigashi 1-chome, Naniwa-ku, Osaka, Japan 556-8601

English (U.S.A.)  
Code No. V0521-5812-6

S  
V  
L  
7  
5  
-  
2

# OPERATOR'S MANUAL

# KUBOTA

# CTL

Compact  
Track  
Loader

MODEL

# SVL75-2

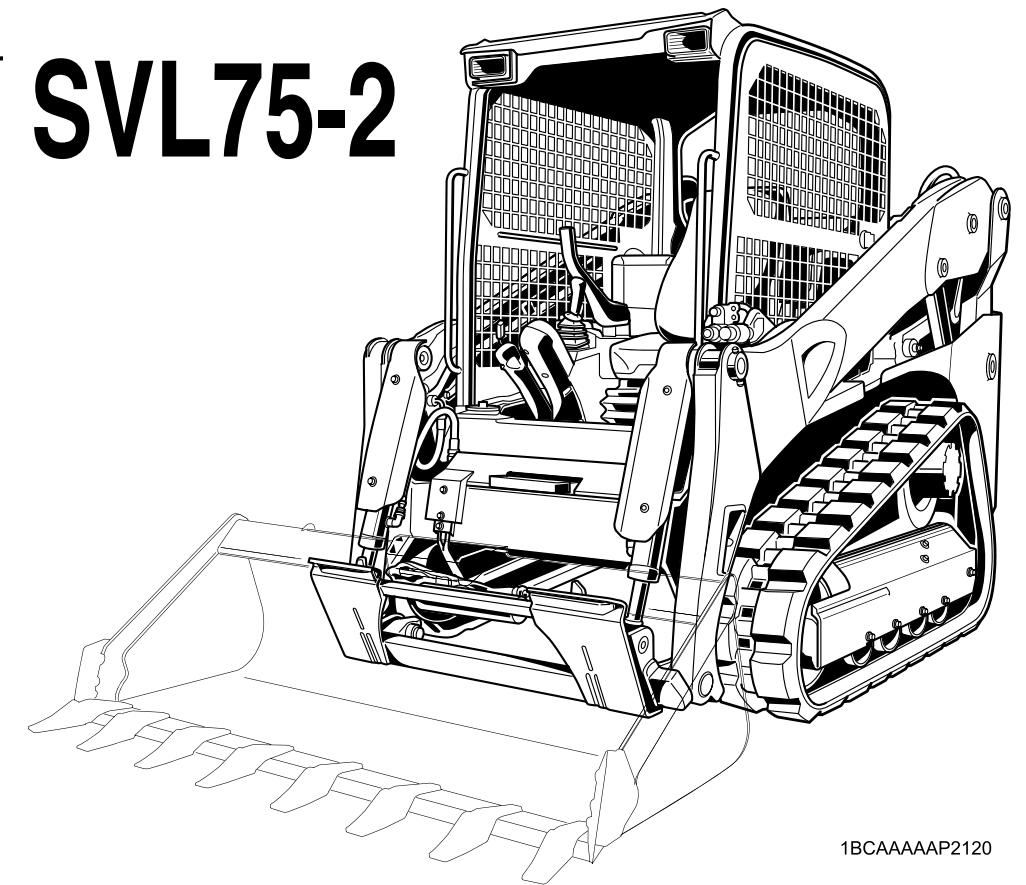

1BCAAAAP2120

READ AND SAVE THIS MANUAL

# Kubota

# ABBREVIATION LIST

Abbreviations	Definitions
API	American Petroleum Institute
ASTM	American Society for Testing and Materials, USA
AUX	Auxiliary
CTL	Compact Track Loader
DIN	Deutsches Institut für Normung, GERMANY
EN	European Standard
ISO	International Standard Organization
JIS	Japanese Industry Standard
FOPS	Falling Objects Protective Structure
MIL	Military Specification and Standard
OPC	Operator Presence Control
OSHA	Occupational Safety and Health Administration
rpm	Revolutions Per Minute
rps	Revolutions Per Second
ROPS	Roll-Over Protective Structure
SAE	Society of Automotive Engineers, USA
SMV	Slow Moving Vehicle
CRS	Common Rail System
DPF	Diesel Particulate Filter
DOC	Diesel Oxidation Catalyst
P/L	Pressure Limiter
SCV	Swirl Control Valve
AFS	Air Flow Sensor
EGR	Exhaust Gas Re-circulation
PCV	Positive Crankcase Ventilation
MAF	Mass Air Flow

California Proposition 65

**⚠ WARNING ⚠**

Engine exhaust, some of its constituents, certain vehicle components and fluids, contain or emit chemicals known to the State of California to cause cancer and birth defects or other reproductive harm.

# UNIVERSAL SYMBOLS

As a guide to the operation of your machine, various universal symbols have been utilized on the instruments and controls. The symbols are shown below with an indication of their meaning.

	Caution		Parking Brake
	Engine, Electrical Preheat		Front Working Light
	Engine Lubricating Oil Pressure		Rear Working Light
	Coolant Temperature		Lock
	Hydraulic Oil Temperature		Unlock
	Hydraulic Lock		Forward
	Hydraulic Unlock		Backward
	AUX Hydraulics		Turn Right
	High-Flow		Turn Left
	AUX Hold		Lift Arm Raise
	AUX Electrical Power		Lift Arm Lower
	Fuel		Loader Bucket, Dump
	Diesel Fuel		Loader Bucket, Rollback
	Fast (Speed Indicator)		Loader Bucket, Float
	Slow (Speed Indicator)		Quick Hitch Lock
	Battery Charge		Horn
	DPF Standby / Regeneration		
	Engine Rev up		
	Inhibit DPF Regeneration		

# FOREWORD

You are now the proud owner of a KUBOTA CTL. This machine is a product of KUBOTA quality engineering and manufacturing. It is made of fine materials and under a rigid quality control system. It will give you long, satisfactory service. To obtain the best use of your machine, please read this manual carefully. It will help you become familiar with the operation of the machine and contains many helpful hints about machine maintenance. It is KUBOTA's policy to utilize as quickly as possible every advance in our research. The immediate use of new techniques in the manufacture of products may cause some sections of this manual to become outdated. KUBOTA distributors and dealers will have the most up-to-date information. Please do not hesitate to consult with them.



## SAFETY FIRST

This symbol, the industry's "Safety Alert Symbol", is used throughout this manual and on labels on the machine itself to warn of the possibility of personal injury. Read these instructions carefully. It is essential that you read the instructions and safety regulations before you attempt to assemble or use this unit.



**DANGER :** Indicates an imminently hazardous situation which, if not avoided, will result in death or serious injury.



**WARNING :** Indicates a potentially hazardous situation which, if not avoided, could result in death or serious injury.



**CAUTION :** Indicates a potentially hazardous situation which, if not avoided, could result in minor or moderate injury.

**IMPORTANT :** Indicates that equipment or property damage could result if instructions are not followed.

**NOTE :** Gives helpful information.

# CONTENTS

- ▲SAFE OPERATION ..... ▲-1
- DEALER SERVICE..... 1
- TECHNICAL DATA..... 2
- DESCRIPTION OF MACHINE PARTS..... 3
- INSTRUMENT PANEL AND CONTROL ELEMENTS..... 4
- CHECKS BEFORE START ..... 7
  - DAILY CHECKS..... 7
  - CHECKING THE SWITCHES ..... 7
    - Hydraulic Unlock Switch ..... 7
    - OPC Switch ..... 7
    - Parking Brake Switch..... 8
    - AUX Port Switch ..... 8
    - Inhibit Diesel Particulate Filter (DPF) Regeneration Switch ..... 8
    - Working Light Switch ..... 9
    - Interior Lamp Switch..... 9
    - Travel Speed Switch..... 10
    - Horn Switch ..... 10
    - AUX Port Variable Switch ..... 10
    - AUX Hold Switch ..... 11
    - AUX Electrical Control Switch (Option)..... 11
    - Float Switch ..... 11
    - Starter Switch ..... 12
    - Hydraulic Quick Switch (Hydraulic Quick-Hitch model only)..... 12
    - Wiper/Washer Switch (Closed cab model) ..... 12
  - CHECKING THE LAMPS AND INDICATORS ..... 13
    - Fuel Gauge Indicator ..... 13
    - Remaining Fuel Warning Lamp ..... 13
    - Coolant Temperature Gauge ..... 14
    - Parking Lamp..... 14
    - Floating Lamp..... 14
    - Warning Lamp ..... 15
    - Glow Lamp..... 15
    - Engine Oil Pressure Warning Lamp ..... 15
    - Battery Charge Lamp..... 15
    - Hydraulic Oil Temperature Gauge ..... 16
    - Hour-Meter..... 16
    - Diesel Particulate Filter (DPF) regeneration indicator ..... 16
    - Engine rev up warning lamp ..... 16
- EXHAUST AFTERTREATMENT DEVICES ..... 17
  - Catalyst-containing Diesel Particulate Filter (DPF) device ..... 17
  - Regeneration of Diesel Particulate Filter (DPF)..... 17
- CHECKING THE SAFETY DEVICES ..... 18
  - Emergency Exit..... 18
  - Armrests Function..... 18
  - OPC Function ..... 18

Forced Lift Arms Lowering Device.....	19
DOOR AND WINDOWS.....	19
Opening/Closing of Cab Door (Closed cab model).....	19
Opening/Closing of Side Cab Window (Closed cab model) .....	21
AIR-CONDITIONER.....	21
Air Flow.....	21
Air Control Vent .....	22
Control Panel.....	23
Operation.....	24
OPERATION OF THE ENGINE.....	25
STARTING THE ENGINE .....	25
Checkpoints after Starting the Engine .....	26
STARTING THE ENGINE UNDER COLD CONDITIONS.....	27
STOPPING THE ENGINE.....	27
STARTING WITH AN AUXILIARY BATTERY .....	27
Observe Following Guidelines when Starting with an Auxiliary Battery.....	27
OPERATION OF THE MACHINE .....	28
RUNNING-IN OF THE MACHINE.....	28
Do not Work with Full Engine Rpm's or Full Loads during the First 50 Working Hours..	28
Oil Change in the Run-in Stage.....	28
STARTING .....	28
Adjusting the Operator's Seat.....	28
Seat Belt.....	29
Armrest .....	29
DRIVING .....	30
Forward and Backward Travel.....	30
TURNING.....	31
Pivot Turn .....	31
Spin Turn .....	32
OPERATION OF THE LIFT ARMS .....	32
Lift Arm Stopper.....	33
OPERATION OF THE BUCKET .....	34
AUXILIARY HYDRAULIC CONTROL .....	35
Auxiliary Hydraulic Control Operation.....	36
ATTACHMENT CONTROL DEVICE (OPTION) .....	37
MECHANICAL QUICK-HITCH .....	37
Attaching Attachments.....	37
Detaching Attachments.....	39
HYDRAULIC QUICK-HITCH (OPTION).....	39
Attaching Attachments.....	39
Detaching Attachments.....	41
IMPORTANT INFORMATION ON MACHINE OPERATION.....	41
Caution While Traveling.....	41
Precaution When Traveling in High Speed.....	42
Precautions for Use of Machine Near Water .....	42
Precaution When Traveling on Inclines .....	42
Parking on an Incline .....	43
Prohibited Actions.....	43
Preventing Slippage of Rubber Tracks.....	43

---

LIFTING THE MACHINE .....	44
TRANSPORTING THE MACHINE .....	47
LOADING THE MACHINE ON A TRANSPORT VEHICLE .....	47
TOWING AN OPERABLE MACHINE .....	49
TOWING AN INOPERABLE MACHINE .....	49
MAINTENANCE .....	50
MAINTENANCE INTERVALS .....	50
OPENING AND CLOSING OF COMPONENTS .....	53
Rear Door .....	53
Engine Hood .....	54
Radiator and Oil Cooler .....	54
Where to Keep Operator's Manual .....	55
Tool Box .....	55
Tilting Up the CAB .....	56
DISCHARGING MUD FROM OPERATOR ROOM AND MAIN FRAME .....	58
Operator room .....	58
Main Frame .....	58
DAILY CHECKS .....	58
Checking Coolant Level .....	58
Checking Fuel Level .....	59
Checking Engine Oil Level .....	59
Checking Hydraulic Oil Level .....	60
Lubrication Points .....	60
Checking Radiator and Oil Cooler .....	61
Checking and Cleaning Engine and Electrical Wiring .....	61
Checking V-belt .....	61
Washing Whole Machine .....	61
Draining Water Separator .....	61
Cleaning Evacuator Valve .....	62
Checking Dust Indicator .....	62
Checking Diesel Particulate Filter (DPF) Muffler .....	62
Checking Washer Liquid .....	62
Checking Battery Condition .....	63
REGULAR CHECKS AND MAINTENANCE WORK .....	65
EVERY 50 SERVICE HOURS .....	65
Draining the Water from the Fuel Tank .....	65
Checking Track Tension .....	65
Inspection and Cleaning Air Cleaner Element .....	66
Air Cleaner Element .....	67
EVERY 250 SERVICE HOURS .....	67
Checking Radiator Hoses and Clamps .....	67
Checking Fuel Line and Intake Air Line .....	68
Adjusting V-belt Tension .....	68
Cleaning Inside of Main Frame .....	69
Replacing Air Cleaner Element .....	69
Cleaning Inner Air Filter .....	69
Cleaning Air Fresh Filter .....	70
Checking Air-Conditioner Condenser .....	70
EVERY 500 SERVICE HOURS .....	71
Changing Engine Oil .....	71

Replacing Engine Oil Filter Cartridge .....	71
Replacing Fuel Filter Cartridge .....	72
Changing Drive Unit Oil (First oil change: 250 hours) .....	72
Changing Return Filter (First filter change: 250 hours).....	72
Replacing Breather Filter .....	73
Replacing Hydraulic Oil Filter (First filter change: 50 hours) .....	73
<b>EVERY 1000 SERVICE HOURS .....</b>	<b>73</b>
Hydraulic Oil Change (Including Replacing Suction and Return Filter in the Hydraulic Tank).....	73
Hydraulic Oil Check with Hydraulic Hammers .....	74
<b>EVERY 1500 SERVICE HOURS .....</b>	<b>75</b>
Checking Injector Tip .....	75
Replacing Oil Separator Element .....	75
Checking EGR Cooler .....	75
<b>EVERY 2000 SERVICE HOURS .....</b>	<b>75</b>
Checking the Alternator and Starter Motor .....	75
<b>EVERY 3000 SERVICE HOURS .....</b>	<b>75</b>
Checking EGR System .....	75
Checking Turbocharger .....	75
Cleaning Diesel Particulate Filter (DPF) .....	75
<b>ANNUAL SERVICING .....</b>	<b>76</b>
Checking Air-Conditioner Pipes and Hoses.....	76
Checking Exhaust Manifold (Cracks, Gas, Leakage and Mounting Screw) .....	76
Checking Intake Air Line for Air Leaks.....	76
Checking Boost Sensor and AFS (Air Flow Sensor) .....	76
Checking Condition of Diesel Particulate Filter (DPF) Muffler .....	76
Checking Diesel Particulate Filter (DPF) Differential Pressure Sensor and Piping for Gas Leak .....	76
Checking Diesel Particulate Filter (DPF) Exhaust Gas Temperature Sensor.....	76
Checking EGR Piping for Gas Leak .....	76
<b>BIENNIAL SERVICING .....</b>	<b>76</b>
Changing Radiator Coolant .....	76
Replacing Fuel Hose .....	77
Replacing Intake Air Line.....	78
Replacement of Radiator Hoses.....	78
Replacing Air-Conditioner Pipes and Hoses.....	78
Replacement of Closed Breather Related Rubber Piping .....	78
Replacement of Diesel Particulate Filter (DPF) Differential Pressure Sensor Rubber Piping (Front and Back).....	78
Replacement of Suction pipe downstream the AFS (Air Flow Sensor) .....	78
Replacement of Boost Sensor Pressure Rubber Piping.....	78
Replacement of EGR Cooler Hose.....	78
<b>SERVICING AS REQUIRED.....</b>	<b>79</b>
Checking Amount of Refrigerant (gas) .....	79
Draining Water Separator .....	79
<b>OTHER ADJUSTMENTS AND REPLACEMENTS.....</b>	<b>80</b>
<b>PURGING OF THE FUEL SYSTEM .....</b>	<b>80</b>
<b>ADJUSTMENT OF TRACKS .....</b>	<b>80</b>
<b>FUSES .....</b>	<b>81</b>
Replacing Fuses.....	81
Fuse Capacities and Circuits.....	82

---

Electrical Outlet.....	82
Slow Blow Fuse .....	82
TROUBLESHOOTING.....	84
List of Error Code Numbers .....	86
OPERATION UNDER COLD WEATHER CONDITIONS .....	92
PREPARATION FOR OPERATION IN COLD WEATHER .....	92
PROCEDURE AFTER COMPLETION WORK .....	92
LONG STORAGE .....	93
RECOMMENDED OILS.....	95
APPENDICES.....	97
MAIN DIMENSIONS .....	97





# SAFE OPERATION

Careful operation is your best insurance against an accident.

**Read and understand this section carefully, before operating the machine.**

Every user, however experienced, should carefully read and understand this section and those of the attachments and accessories before taking the machine into operation. The owner is obliged to inform the operators of these instructions in detail.

Keep this manual in the storage place. (See "Where to keep Operator's Manual" in "MAINTENANCE" section.)

## 1. BEFORE OPERATION

1. Know your equipment and its limitations. Read and understand this entire manual before attempting to start and operate the machine.
2. Obey the danger, warning and caution labels on the machine.
3. For your safety, a ROPS/FOPS (Roll-Over Protective Structure/Falling Objects Protective Structure) with a seat belt is installed by KUBOTA. Always use the seat belt when the machine is equipped with the ROPS/FOPS as this combination will reduce the risk of personal injury or death, should the machine be upset. Do not modify structural members of ROPS by welding, drilling, bending, grinding or cutting, as this may weaken the structure. If any component is damaged, replace it. Do not attempt repairs. If the ROPS is loosened or removed for any reason, make sure all parts are reinstalled correctly. Tighten mounting bolts to proper torque.

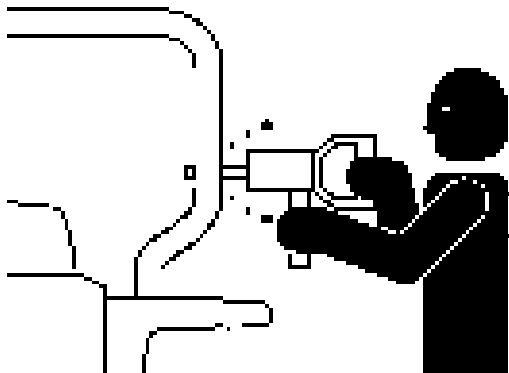

4. The ROPS/FOPS structure complies with ISO 3471, ISO 3449 and OSHA regulations.
5. The seat belt must be inspected regularly and replaced if frayed or damaged.

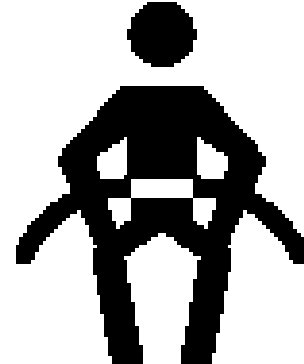

6. Always sit in the operator's seat when starting the engine or operating the levers or controls.
7. Do not operate the machine while under the influence of alcohol, medication, controlled substances or while fatigued.
8. Check the surrounding area carefully before using the machine or when attachments are being connected. To avoid any danger of electrocution, never operate the machine near power lines before confirming the power is off and all local and national safety regulations. Never approach a machine or load that is contacting a power source such as power lines. Electrocution can occur by coming into contact with a machine that is near power lines.
9. Check for buried pipes and cables before digging.
10. Check for hidden holes, obstacles, soft underground, and overhangs. Do not enter soft ground.
  - During machine use, do not allow any persons within the working range.

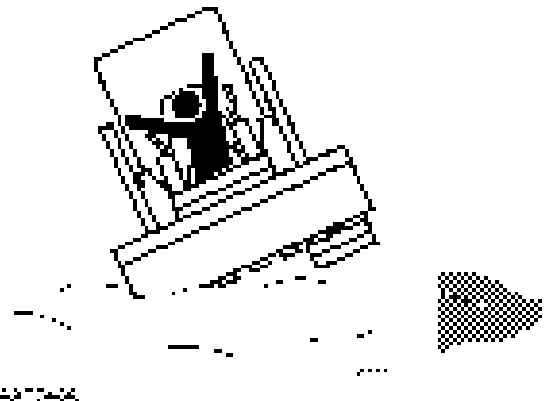

11. Do not allow anyone to use the machine until they have been informed of the work to be performed and they have read and understood the operator's manual.
12. Do not wear baggy, torn or oversized clothing when working with the machine as such clothing can get caught in rotating parts or control elements which can cause accidents or injuries. Wear adequate safety clothing, e.g. safety helmet, safety shoes, eye protection, ear protection, working gloves, etc. as necessary and as prescribed by law or statutes.

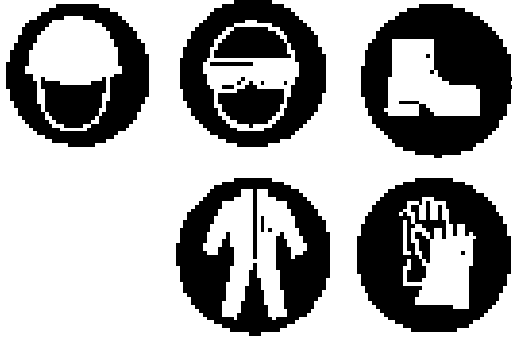

4-2-3-3-1-1

13. Do not allow passengers to ride on any part of the machine at any time. The operator must remain in the machine seat during operation.
14. Check the levers, pedals and mechanical parts for correct adjustments and wear. Replace worn or damaged parts immediately. Check the nuts and bolts regularly for correct torque.
15. Keep your machine clean. Heavy soiling, grease, dust and grass can cause fires, accidents or injuries.
16. Before starting the machine, be absolutely sure that the machine has been filled with fuel, lubricated, greased and undergone all necessary maintenance.
17. Do not modify the machine, otherwise it could lead to unforeseen safety problems.
18. Make sure attachments, particularly those utilizing quick-hitch, are securely mounted. Use only KUBOTA authorized attachments.

## 2. OPERATING THE MACHINE

1. Mount and dismount the machine safely. Always face the machine. Always use handrails and available steps and keep yourself well balanced. Do not grab or hold any of the control levers and switches. Do not jump on or off the machine, whether stationary or in motion.
2. Start and control the machine only from the operator's seat. The operator should not lean out of his/her seat when the engine is running.
3. Before starting the engine, make sure that the armrests are in the "Raised" position and the control levers are in their neutral position and the seat belt is fastened correctly.
4. Always thoroughly check the surrounding area for any possible conditions that could create a dangerous situation.
  - Make sure you read the operator's manual to thoroughly understand the operating conditions and limitations of the machine.
  - To avoid damage and to prevent accidents, always use the buddy system and have the other person, check for clearances and other possible dangers that may be obstructed from view.
  - Never allow people to approach the vicinity of the turning radius of the machine.
  - Be cognizant of blind spots to the rear and always check behind you before backing up.
5. Only operate the machine in well-ventilated area to avoid poisoning from carbon monoxide, an odorless, colorless gas that is deadly.

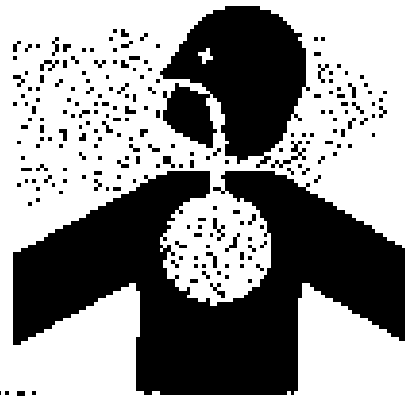

4-2-3-3-1-2

6. Never remove any of the safety features on the machine.
  - Make sure all safety features, including guards, protective devices, doors and cabin, are functioning normally, properly secured and in good condition. Repair and replace any lost or damaged protective features.
  - Carefully read the operator's manual in order to understand the proper use of safety features such as armrest, seat belt, and other equipment. Make sure you use them properly.
  - Make sure all safety features are in good operating condition and remove only when repair is needed.
7. To avoid injury, always keep hands and body inside the ROPS/FOPS (protective structures) whenever operating the machine. Never try to operate machine using control levers from outside the operator's cabin while the machine is running.
8. Always keep the heavy end of the machine up when traveling up or down an incline to avoid any possibility of machine rolling over.
9. Place that bucket at a distance of 20 to 30 cm (8 to 12 in.) from the ground when moving up or down an incline. Be prepared to lower the bucket to the ground in case of emergency.
10. To avoid injury or accidents, always operate the machine or the equipment at slow speed when going up or down an incline by reducing the engine speed (rpm). Place the stroke of the left control lever at half speed or less when going down an incline. Traveling too fast down an incline can cause the operator to lose control of the machine.
11. Avoid stopping suddenly on an incline, which can cause the machine to become unstable and rollover.
12. Never cross an incline horizontally or at an angle, which can cause the machine to rollover. Approach inclines vertically to avoid loss of control.
13. Take care when moving the machine in slippery or unstable surfaces such as grass, fallen leaves, metal plates, or ice, as it may skid out of control. Do not allow the machine to be oriented diagonally to such surfaces.
14. Watch where you are going at all times. Watch for and avoid obstacles. Remain alert for trees, wires and other obstructions.
15. Avoid any sudden movements while moving and operating the machine such as stopping, starting or turning. Do not raise armrests while the machine is in motion as this will cause the parking brake to engage and could cause an accident or injury.
16. Avoid driving the machine over any obstacles, which could cause loss of control. If an obstacle cannot be avoided, always place the bucket close to the ground and move slowly over the obstacle. Do not approach an obstacle at an angle, which could cause the machine to rollover.
17. Avoid performing any work with the machine when it is on an incline, which could cause it to become unbalanced and rollover. Always take care when moving the machine on an incline. Always make sure the heavy end of the machine is facing up the incline when moving it up or down the incline.
 



With bucket on



With bucket raised
18. Always use caution when floating the lift arms.
  - Always make sure the bucket is lowered to the ground before floating the lift arms. Floating the lift arms when the bucket is raised could cause an accident or injury from the bucket falling.
  - Never move forward when the lift arms are in the "float" position.
19. Never dig or shovel at high speed, which could cause the operator to be thrown from the operator's cabin or cause injury from hitting something when the machine stops suddenly. Always operate the machine at low speed, carefully checking the area in front of the load you will be moving.
20. Never operate the machine with the bucket raised over the heads of people. Accident or injury may occur from objects falling from the bucket or the bucket itself falling.
21. Beware of material falling from the bucket. Unstable material in the bucket such as round, cylindrical, or stacked items could fall from the bucket, causing injury. Always move an unstable load with the bucket lowered.
22. Any sudden movements of the machine such as lowering or stopping of the attachment may cause it to recoil and rollover. Pay particular attention when the bucket is loaded.
23. Never exceed the maximum loading capability of the bucket or put loads off-center of the bucket, which can cause the machine to become unstable and rollover.

24. Never attempt to undercut a high embankment. Always carefully check the area for conditions that could cause the ground to cave-in.

- Never operate in areas where there is a possibility of falling rock.
- Never attempt to operate or drive the machine on unstable surfaces such as cliffs, shoulder of roads, deep trenches, etc. The machine could lose stability from unstable ground or vibration underneath, causing it to rollover or fall.
  - (1) Ground surfaces are especially unstable after heavy rain or explosions.
  - (2) Embankments and trenches may cause instability of the ground around the area.

25. Always operate the machine at a safe, low speed, especially in congested or closed-in areas where there is a danger of hitting or running into something. Pay close attention to obstructions.

26. Pay particular attention when passing through tunnels or moving the machine near high walls to avoid hitting it and causing an accident or injury.

Always check height and width dimensions of the machine against tunnels or any other narrow spaces through which the machine is to be moved in order to avoid an accident or injury from hitting an obstruction.

27. The machine is NOT designed for operation with hanging loads and has no safety features for such circumstances. Never operate in conjunction with a crane or other such device, which could cause serious injury.

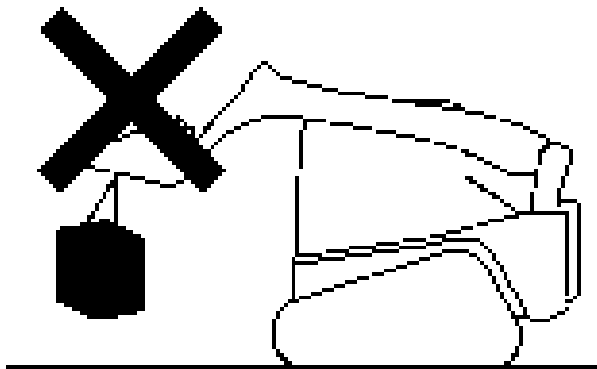

FIGURE 2

### ◆ Safety for children

Tragedy can occur if the operator is not alert to the presence of children. Children generally are attracted to machines and the work they do.

1. Never assume that children will remain where you last saw them.
2. Keep children out of the work area and under the watchful eye of another responsible adult.
3. Be alert and shut your machine down if children enter the work area.
4. Never carry children on your machine. There is not a safe place for them to ride. They may fall off and be run over or interfere with your control of the machine.
5. Never allow children to operate the machine even under adult supervision.
6. Never allow children to play on the machine or on the attachments.
7. Use extra caution when backing up. Look behind and down to make sure the area is clear before moving.

### 3. AFTER OPERATION

Before leaving the machine:

- Park the machine on a firm, flat and level surface. If this is not possible, block the machine securely to prevent movement.
- Lower the attachments to the ground.
- Stop the engine.
- Remove the key.

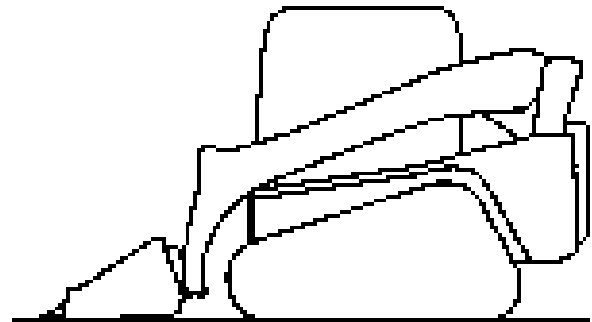

FIGURE 3

#### 4. SAFE LOADING AND TRANSPORT OF THE MACHINE

1. Observe all regulations concerning the transport of the machine on public roads.
2. Use adequately long and robust ramps when loading on the machine. Block the ramps and transport appropriately. If towing is required, use proper tow lines and attachment points. (for details, see "LOADING THE MACHINE ON A TRANSPORT VEHICLE" section)
3. To avoid tipping over, the heaviest end of the unit should proceed up the ramps first, do not change the running direction and do not swing the attachment crosswise to the loading ramps.
4. Lower the attachment on the loading bed and release the pressure from the hydraulic system. After loading the machine on the truck, secure the tracks with blocks and tie down the machine at the appropriate locations.



FIGURE 10

- (1) Chain
- (2) Block

5. Avoid abrupt braking of the vehicle with the machine loaded. Sudden braking could cause the machine to move and could cause a serious accident.

#### 5. MAINTENANCE

Before doing maintenance work on the machine, place the machine on a firm, flat and level surface, lower the lift arms slowly to the ground, stop the engine, remove the key.

When dismantling hydraulic parts, make sure that the hydraulic oil has cooled down sufficiently to avoid burns. Start maintenance work carefully, e.g. loosen the plug slowly so that oil will not squirt out.

1. Before working on the engine, the exhaust system, the radiator and the hydraulic system, let the machine cool down sufficiently.
2. Turn off the engine at all times when filling with fuel. Avoid spilling and over-filling of fuel.
3. Smoking is prohibited while refueling or handling the battery. Keep sparks and fire away from the fuel tank and battery. Flammable gases escape from the battery, especially during charging.
4. Read and follow the directions "STARTING WITH AN AUXILIARY BATTERY" in "OPERATION OF THE ENGINE" section, when starting with an auxiliary battery.
5. Keep a first-aid box and extinguisher at hand at all times.
6. Do not open the radiator cap before the radiator has cooled down sufficiently. First loosen the cap to the first stop and allow the system enough time to release the remaining pressure. Then loosen the cap completely.

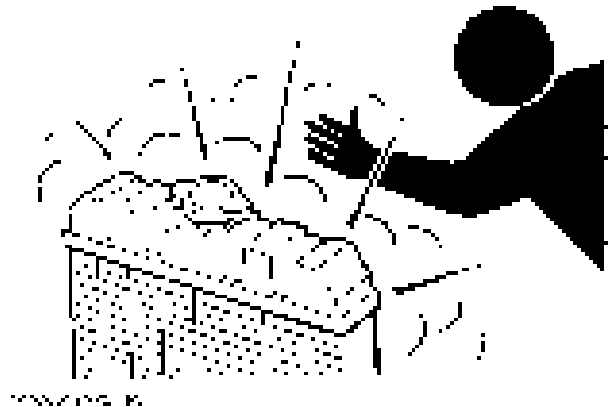
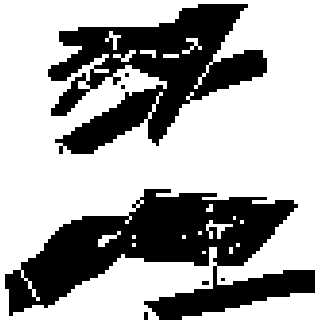

FIGURE 11

7. To avoid short-circuiting the battery, always remove the ground cable first and attach the positive cable first.
8. Oil under high pressure can penetrate the skin and may be harmful to your health if not treated immediately.

9. Leaking hydraulic fluid has enough pressure to penetrate the skin and cause serious injuries. Leakages from pinholes can be totally invisible. Do not use hands for checking for leaks. Always use a piece of wood or cardboard. It is strongly recommended to use a face mask or eye protection. Should injuries occur with leaking hydraulic fluid, contact a doctor immediately. This fluid can cause gangrene or serious allergic reactions.



▲-6-10

- 10. To avoid environmental damage from acid and heavy metals, dispose of the battery appropriately.
- 11. Observe all laws and regulations concerning the disposal of used oil, coolants, solvents, hydraulic fluids, battery acids and batteries.
- 12. To avoid fire, do not heat the hydraulic components (tanks, pipes, hoses, cylinders) before they have been drained and washed.
- 13. Use a face mask or eye protection to protect the eyes and respiratory system against dust and other foreign particles.

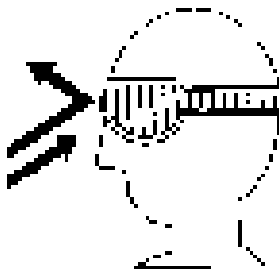

▲-6-11

14. Securely support the machine with stands or suitable blocking before working underneath. For your safety, do not work under any hydraulically supported devices. They can settle, suddenly leak down, or be accidentally lowered.

- 15. Do not dismantle the spring of the track tensioner. If dismantling is necessary, contact your KUBOTA dealer where the machine was purchased, or competent service shop. The assembly must be done according to the KUBOTA workshop manual (W.S.M.) for the product involved.
- 16. Always attach a "DO NOT OPERATE" tag whenever performing any kind of maintenance or repair.
- 17. Make sure you have the proper tools on hand. Do not use defective or damaged tools, gauges, or other devices. Always use tools that are appropriate for the task to be done.
- 18. To prevent personal injury or death, be sure to use explosion-proof lighting when working on, inspecting or handling fuel, oil, coolant, battery fluid, etc. If the explosion-proof lighting is not used and should break, it can ignite and cause fire, injury or death.
- 19. Prohibit unauthorized persons from entering the work area to prevent injury caused by debris flying off of machine parts during grinding, welding, using a hammer or other such tasks.
- 20. Make sure work area is clear and safe. Be sure to work on a firm, level surface with adequate lighting. Work in well-ventilated area if indoors. Make sure the area is free from any potentially dangerous conditions such as obstacles, slippery surfaces, etc.
- 21. Be sure the machine is clean and free of debris.
  - Always remove debris from the machine and clean it before performing any maintenance or repair work.
  - Before using water to wash or clean the machine, stop engine and make sure all electrical parts and devices are covered. Any water seepage into electrical wiring on the machine can cause a short circuit or malfunction of controls. Never wash the battery, sensors, connectors or operator's cabin with water or steam.

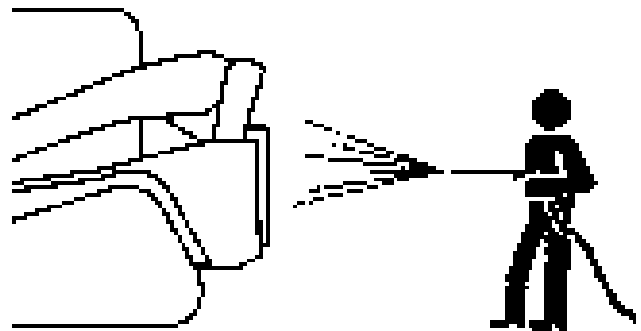

▲-6-12

22. Always make sure the engine is stopped before performing any maintenance or repairs.

- Do not attempt to lubricate or make mechanical adjustments while the machine is in motion or while the engine is running even if stationary.
- If you must perform some maintenance procedures when the engine is running, make certain one other person is assisting by sitting in the operator's cabin while the work is being performed elsewhere on the machine. Always keep body clear of any moving parts and remove any loose clothing when working near moving parts to prevent possible injury.
- Always stay clear of moving parts. Clothing, hands or other parts of the body can become caught in moving parts of the machine and cause personal injury or death.
- Make sure to avoid any rotating fans, V-belt and other such moving parts. Never insert tools, fingers, hands, etc. while these parts are running.



23. Be sure to place blocks around the machine and place protection where components could fall.

- Always make sure the bucket is at the lowest possible position or on the ground before performing any maintenance or repairs under the machine.
- Make sure the tracks are securely blocked off.
- Whenever performing maintenance or repairs when the lift arms are raised, always use the lift arm stopper.
- Never do any work under a machine or work on it while it is hoisted on jack-stands or other rigid support devices unless they are well secured and stable.

24. Make sure the raised lift arms are properly and securely blocked.

- Make sure the lift arm stopper is properly engaged before performing any work beneath raised lift arms. Never attempt to do any work or move under the lift arms when they are not properly supported.
- Keep in mind that the lift arms may fall whenever hydraulic lines are disconnected, loosened, or removed. Any malfunction or failure in the hydraulics can also cause lift arms to drop.
- Always perform the necessary repairs or service whenever the lift arm stopper becomes damaged or malfunctioned, or part(s) are missing. Damaged or malfunctioning lift arm stopper may cause the lift arms to fall causing personal injury or death.

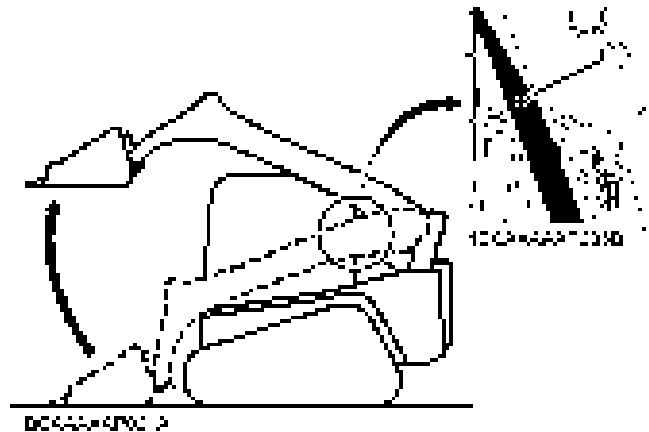

(1) Lift arm stopper

25. Always secure the rear door after opening it. Avoid opening the rear door when the machine is on an incline or in strong winds.

26. Precaution on tilting the cabin.

- Do not raise or lower the cabin while the engine is running as it may move, cause the machine to become unstable, resulting in personal injury or death. Always lower the working parts of the machine to the ground and stop the engine before attempting to raise or lower the cabin.
- Make sure the cabin is properly and securely supported with a stopper when tilted to prevent it from falling and causing personal injury.

27. Use care when refueling.

- Never smoke cigarettes or permit the use of fire while refueling or in the vicinity of refueling.
- Always make sure the engine is off and cool before removing the fuel cap to refuel the tank. Avoid getting fuel on any hot components.
- Keep control of the fuel filler nozzle while refueling.
- Never overfill the tank with fuel. Leave room for thermal expansion.
- Always remove any excess or spilled fuel immediately.
- Always make sure the fuel tank cap is securely reinstalled. Replace the cap only with a manufacturer approved cap whenever it becomes damaged. Use of the wrong type of cap may not allow for proper venting, causing pressure in the tank to build up.
- Never use fuel to clean the machine.
- Always use the correct type of fuel for the machine and the temperature in which it is being operated.

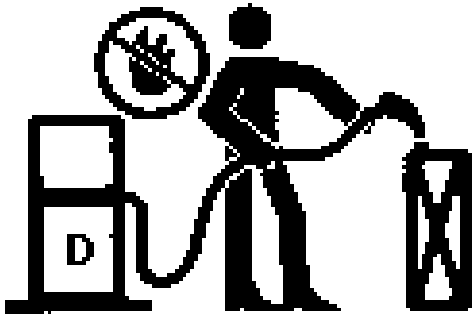

XXXXXXXXXX

28. Hoses

- Leakage in any fuel, oil or hydraulic line can cause fire or explosion.
- Avoid any twisting, bending or hitting of hoses that could cause damage to the line.
- Make sure any loose connections are secure properly before using the machine.

29. Fire prevention

Compact Track Loader and some attachments have components that are at high temperatures under normal operating conditions. The primary source of high temperatures is the engine and exhaust system. The electrical system, if damaged or incorrectly maintained, can be a source of arcing or sparks.

The following fire prevention guidelines will help to keep your equipment up and running efficiently and keep the risk of fire to a minimum.

- Blow off all accumulated debris near hot engine exhaust components such as turbocharger and exhaust manifold as well as exhaust pipes and muffler more frequently when working in severe conditions.

- Clean out all accumulated flammable debris such as leaves, straw, pine needles, branches, bark, small wood chips and any other combustible materials from inside the machine belly pans or lower unit structures as well as from area in proximity to the engine.
- Inspect all fuel lines and hydraulic hoses for wear or for deterioration. Replace them immediately if they begin to leak.
- Examine electrical wiring and connectors frequently for damage. Repair any wires that are loose or frayed before operating the machine. Clean all electrical connections and tighten all electrical connections as necessary.
- Inspect the exhaust system daily for any signs of leakage. Check for broken pipes and muffler and also for loose or missing bolts, nuts and clamps. If any exhaust leaks or fractured parts are found, repairs must be completed prior to operation.
- Always keep a multipurpose fire extinguisher on or near the machine. Be familiar with the operation of the fire extinguisher.

30. Take care when working around hot and pressurized components.

- Always allow the engine to cool sufficiently before performing any maintenance, inspection or repairs.
- Never touch any parts such as the engine, muffler, radiator, hydraulic lines, sliding parts, etc. as they may be very hot immediately after the machine has been running and can cause burning. Allow these parts to cool sufficiently before touching.
- Always use sufficient care whenever removing the caps and plugs on the coolant, oil and hydraulic fluid as they are hot and pressurized and can cause burning and injury from spraying of hot fluid.



XXXXXXXXXX

31. Make certain pressure from all of these systems is sufficiently released before performing any maintenance or repairs. Oil or other fluids could be released when caps or filters are removed before the pressure has been stabilized in the hydraulic system.

- Gradually release internal pressure build-up by standing out of the line of any possible spray and slowly removing plugs, screws or disconnect hoses.

32. Always use care whenever handling grease that is pressurized.

- Always follow the proper procedure to adjust tension. Grease in the track adjuster is pressurized and improper release can cause the discharge valve to fly off, causing personal injury or death.
- Always loosen the discharge valve for the grease slowly.
- Avoid standing in front of, or putting any parts of the body in the line of the grease discharge valve.
- If no grease is released when discharge valve is loosened, the machine has a malfunction. DO NOT attempt to make any repairs yourself and contact the nearest dealer for repairs. Any operation of the machine under these conditions can be very dangerous.

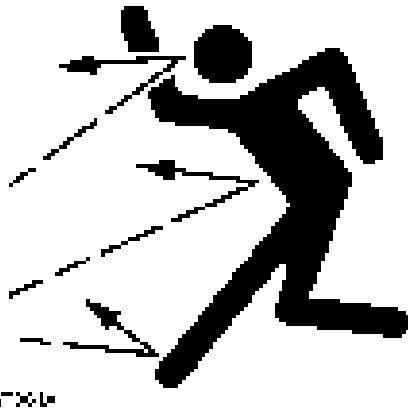

33. Always carefully check the machine after performing any maintenance or repairs. Confirm that no oil, water, etc., is leaking from any parts that had been serviced by carefully inspecting the parts. Gradually speed up the engine from a low speed to higher speed to check operation.

34. Waste material

- Always make sure any material and waste products from the repair and maintenance of the machine are collected into proper containers using a funnel, or other device. Dispose of waste material properly to avoid pollution and contamination of the environment.
- Consult local regulations and codes when disposing of oil, fuel, engine coolant, refrigerant, solvents, filters, batteries, and any other potentially harmful and hazardous material or substance.

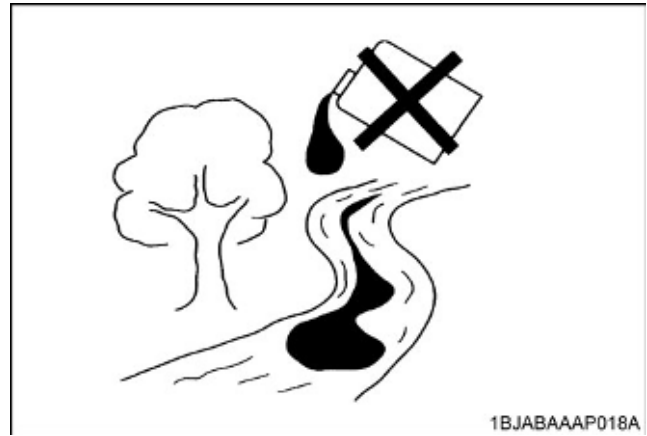

35. To avoid the possibility of battery explosion, do not use or charge the refillable type battery if the fluid level is below the LOWER (lower limit level) mark. Check the fluid level regularly and add distilled water as required so that the fluid level is between the UPPER and LOWER levels.
36. To avoid sparks from an accidental short circuit, always disconnect the battery's ground cable (-) first and reconnect it last
37. Do not open high-pressure fuel system. High-pressure fluid remaining in fuel lines can cause serious injury. Do not disconnect nor attempt to repair fuel lines, sensors, or any other components between the high-pressure fuel pump and injectors on engines with high-pressure common rail fuel system.
38. To avoid hazardous high voltage, turn the key switch to the OFF position if it is necessary to check to repair the computer, harness or connectors.
39. When the Diesel Particulate Filter (DPF) is in the regenerating cycle, the exhaust gas and the DPF muffler become hot. During regeneration, take into account that the muffler will be very hot and keep the machine away from other people, animals, plants, and flammable material. Also keep the area near the DPF muffler clean and away from flammable material.
40. The DPF-regeneration-caused exhaust gas may adversely affect people, animals and plants. Before this action, look around the machine for added safety.



① Part No. 41811-5734-1 (R-4th floor)

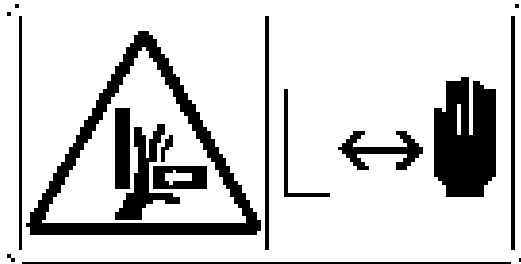

EBC66497-000

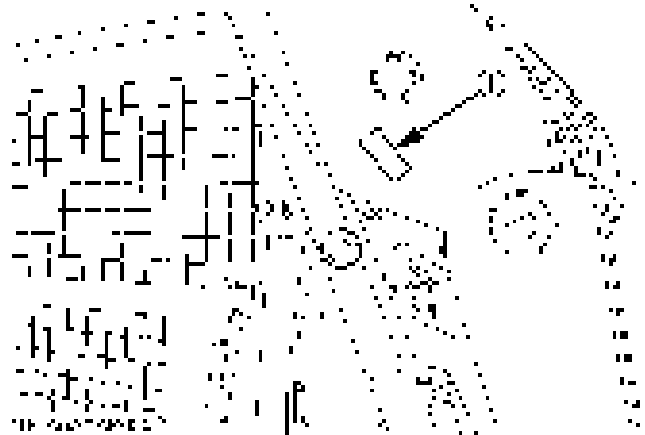

② Part No. 43211-5741-2

**▲WARNING**

TO AVOID PERSONAL INJURY OR DAMAGE TO THE MACHINE, DO NOT OPERATE THE MACHINE WITH THE HANDS ON THE HAND GUARD. See Operator's Manual.

EBC66497-000

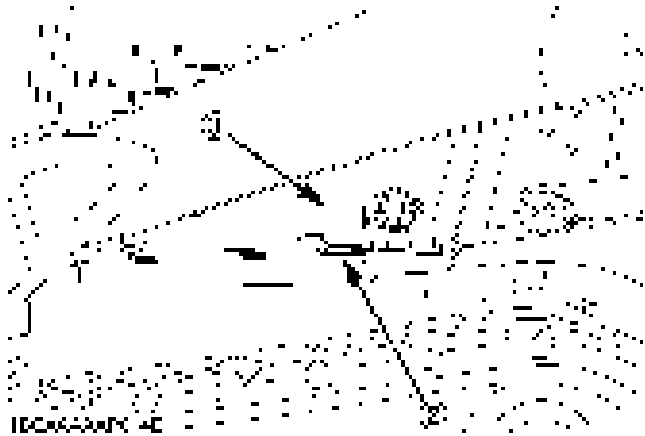
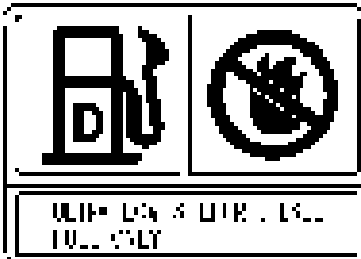
③ Part No. 41120U-5429-1  
Hand Safety     No. 100

EBC66497-000

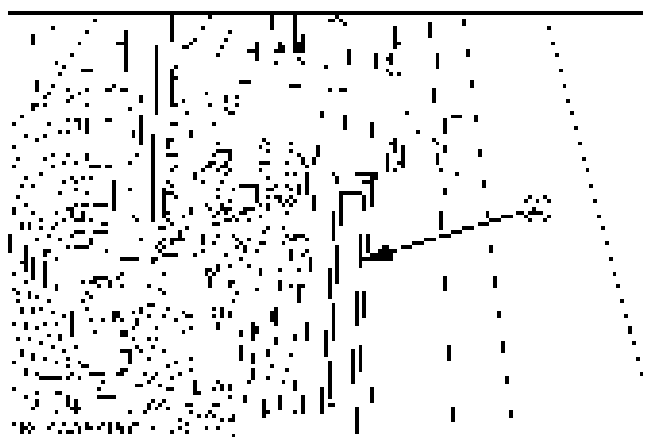

④ Part No. 43211-5740-1

**▲WARNING**

ULTRASONIC WELDING: DO NOT OPERATE. To reduce the risk of injury, do not operate the machine with your hands on the hand guard. See Operator's Manual.

EBC66497-000

10) Part No. V0011-5700-1

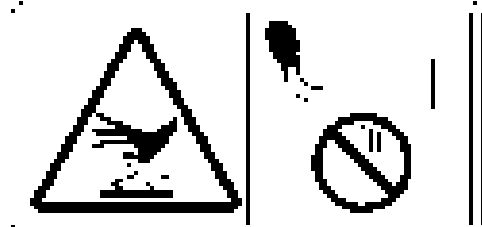

10000000000

20) Part No. V0011-5700-1



10000000000

30) Part No. B01514500-1

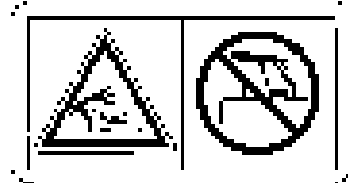

10000000000

40) Part No. V0021-5704-1

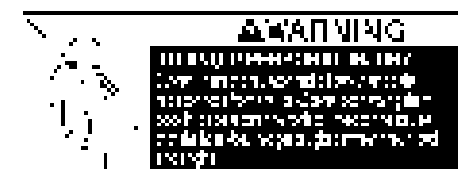

10000000000

50) Part No. V0021-5704-1



10000000000

60) Part No. T0000-0000-1

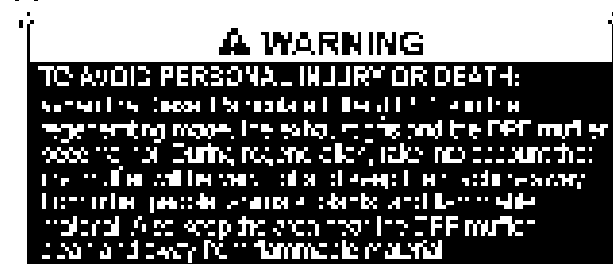

10000000000

70) Part No. V0011-5704-1 (Both sides)  
 Do not raise the base until the PFF is secured.

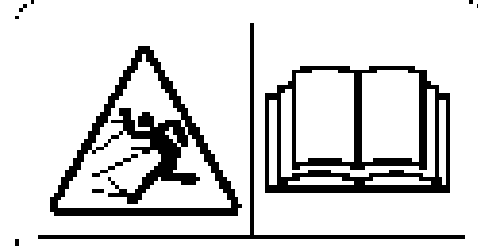

10000000000

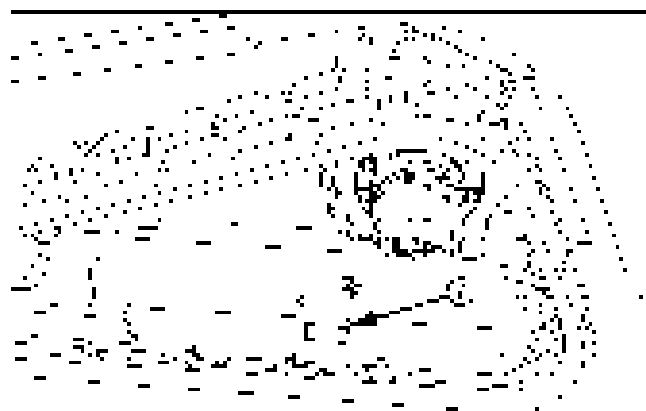
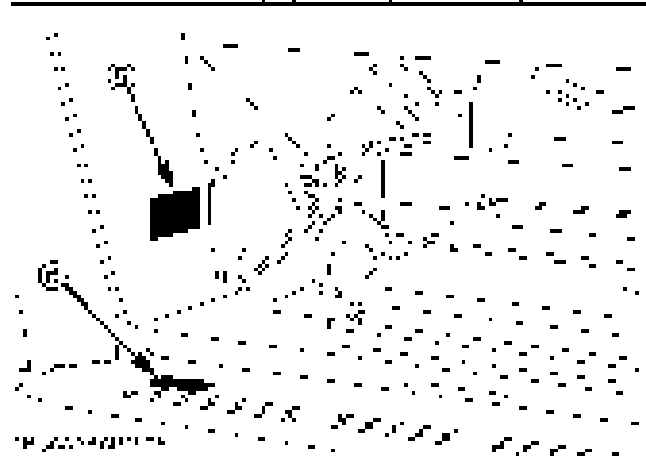

10000000000



⑩ PREVENT VOLTAGE



⑩ 0000000000

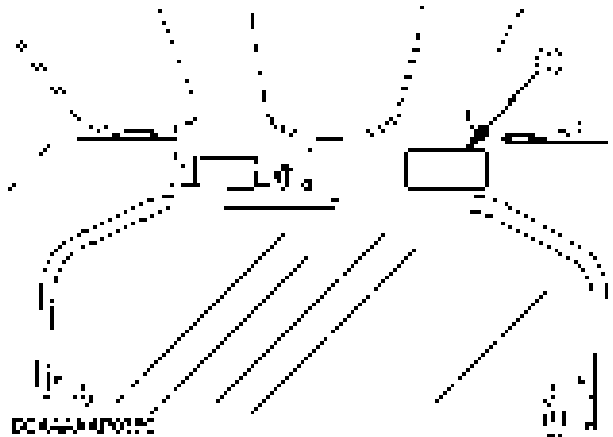

⑪ Do Not Enter (Excluded)

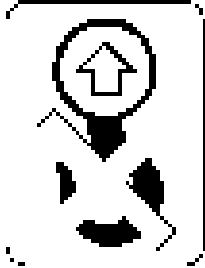

⑪ 0000000000



## 7. CARE OF DANGER, WARNING AND CAUTION LABELS

1. Keep danger, warning and caution labels clean and free from obstructing material.
2. Clean danger, warning and caution labels with soap and water, and dry with a soft cloth.
3. Replace damaged or missing danger, warning and caution labels with new labels from your KUBOTA dealer.
4. If a component with danger, warning and caution label(s) affixed is replaced with new part, make sure new label(s) is (are) attached in the same location(s) as the replaced component.
5. Mount new danger, warning and caution labels by applying on a clean dry surface and pressing any bubbles to outside edge.

# DEALER SERVICE

Your KUBOTA dealer is always ready to help so that your machine offers the best performance. After having carefully read these instructions, you will realize that much of the routine maintenance can be done by yourself. Your KUBOTA dealer is responsible for servicing and the delivery of spare parts. When ordering spare parts from your KUBOTA dealer, always mention the serial number of the machine and the engine.

Note these numbers right away in the supplied lines.

	Model	Serial No.
Machine		
Engine		
Dealer's name (To be filled in through the owner)		

◆ **Warranty policy**

The Product(s) described in this Operator's Manual are designed and manufactured only for the country in which they are initially wholesaled by Kubota or one of its affiliated companies. Neither Kubota Corporation nor its affiliated companies provide warranty for any Product which is re-sold or retailed in any country other than the country for which the Product(s) were designed or manufactured.

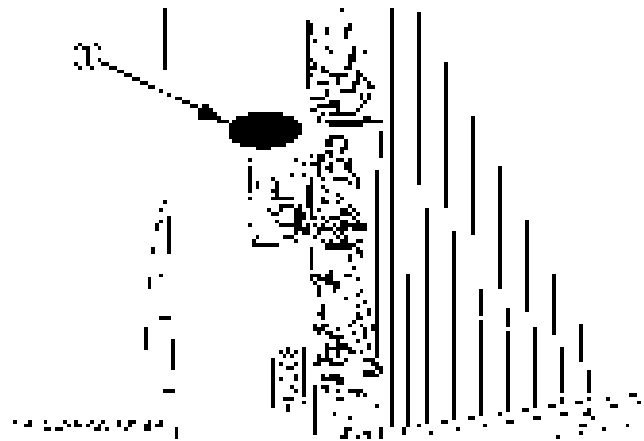
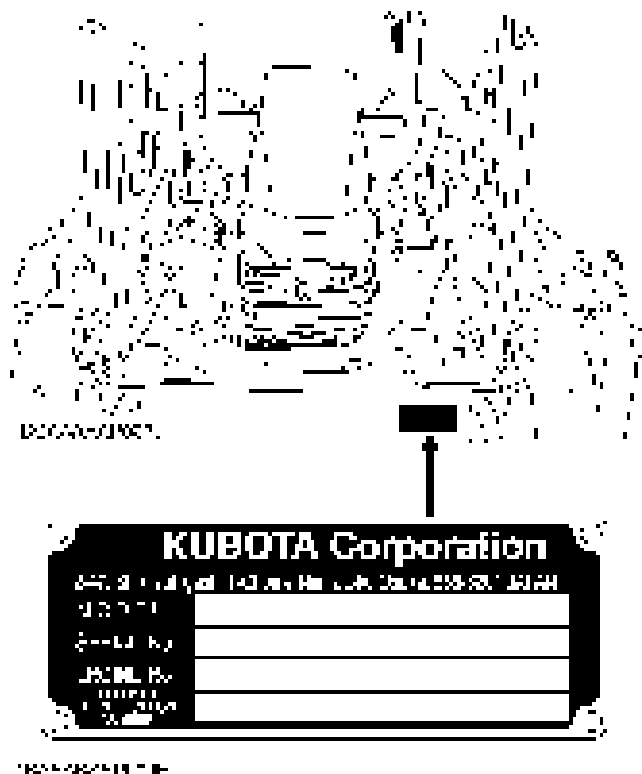

(1) Machine serial No.



(1) Engine serial No.

# TECHNICAL DATA

		KUBOTA CTL (Compact Track Loader)		
Model name		SVL75-2		
Type		Open Cab	Closed Cab	
Operating weight (including operator's weight) kg(lbs.)		4100 (9039)	4225 (9314)	
Engine	Type	Water cooled 4 cycle diesel engine with 4 cylinder EPA Tier 4		
	Model name	KUBOTA V3307-CR-TE4		
	Total displacement	cc(cu.in)	3331 (203.3)	
	Engine power	SAE J1995 gross kW(HP)	55.4 (74.3)	
		SAE J1349 net kW(HP)	51.3 (68.8)	
	Rated speed	rpm	2400	
	Low idling speed	rpm	1150	
Performance	Rated operating capacity	kg(lbs.)	1043 (2300)	
	Tipping load	kg(lbs.)	2980 (6570)	
	Breakout force	Bucket	kg(lbs.)	2814 (6204)
		Lift arm	kg(lbs.)	2162 (4766)
	Travel speed	Fast	km/h(mph)	11.5 (7.1)
		Slow	km/h(mph)	7.5 (4.7)
	Ground pressure (With operator)	kPa (kgf/cm <sup>2</sup> ) [psi]	Standard track	Wide track
39.2 (0.40) [5.6]			33.0 (0.34) [4.7]	
Battery capacity		12V RC: 1600 min, CCA 900A		
Pressure connection for attachments	Max. displacement (Theoretical) L(US gal)/ min	66.0 (17.4)		
	Max. pressure Mpa (kgf/cm <sup>2</sup> ) [psi]	22.0 (224) [3185]		
Fuel tank capacity		L(US gal)	93 (24.6)	

**NOTE :**

- Specifications subject to change without notice.

# DESCRIPTION OF MACHINE PARTS

[Front view]

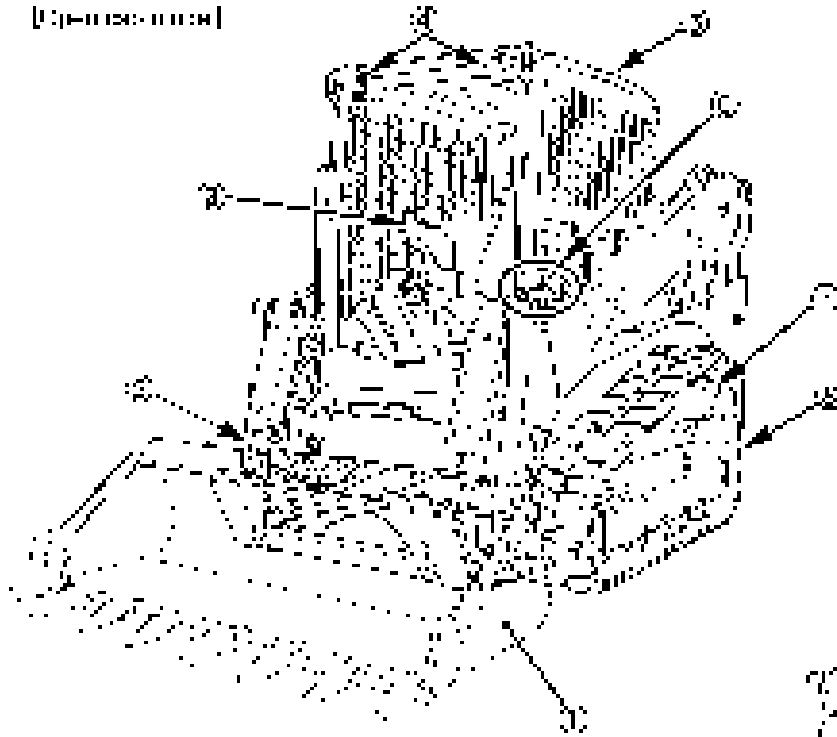

[Rear view]

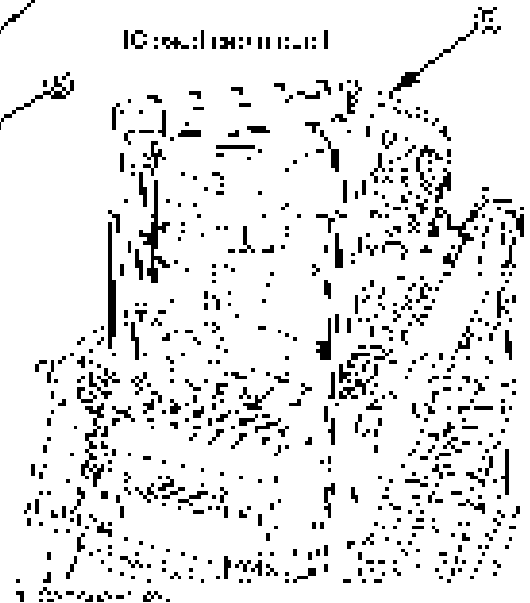

[Left side view]

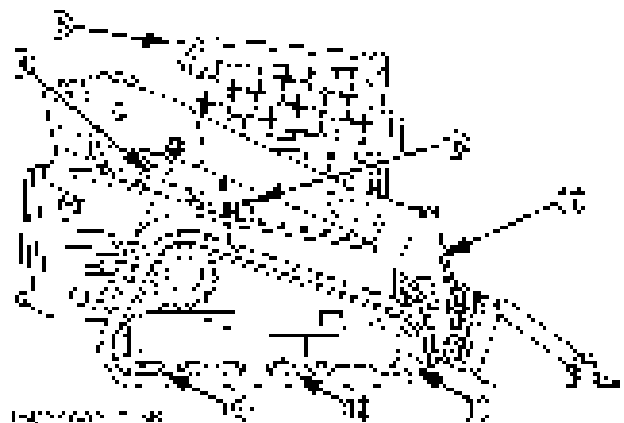
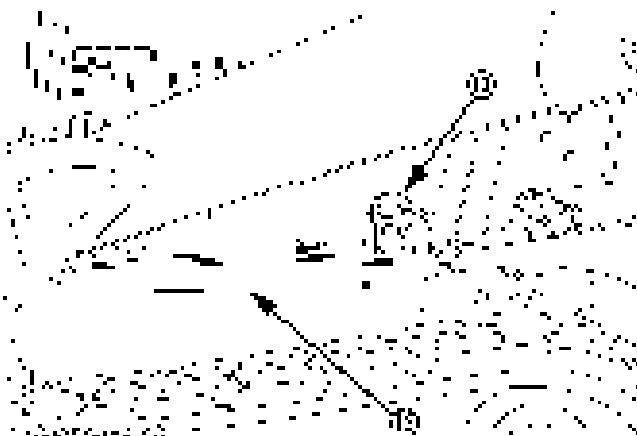

**DEPICTED CONTENTS**

- |                                 |                     |                         |                         |
|---------------------------------|---------------------|-------------------------|-------------------------|
| (1) Bucket                      | (6) AUX supply port | (11) Front idler        | (16) Hydraulic tank cap |
| (2) Tilt cylinder               | (7) Drive motor     | (12) Lift arm stopper   | (17) Lift arm           |
| (3) Armrest                     | (8) Rubber track    | (13) Fuel tank cap      |                         |
| (4) Front working light         | (9) Rear idler      | (14) Lift arm cylinder  |                         |
| (5) Cab (Open cab / Closed cab) | (10) Track roller   | (15) Rear working light |                         |

# INSTRUMENT PANEL AND CONTROL ELEMENTS

## ■ Switch

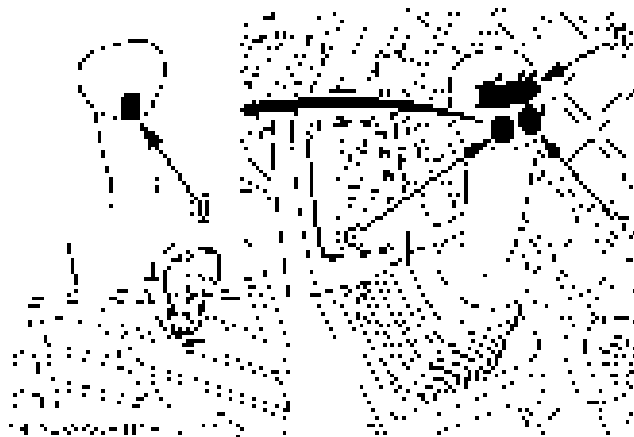
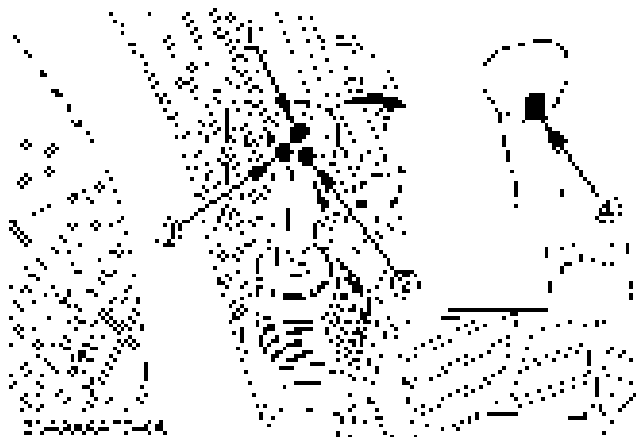

### DEPICTED CONTENTS

- (1) Horn Switch
- (2) AUX electrical control switch (Right)
- (3) AUX electrical control switch (Left)
- (4) Travel speed switch
- (5) AUX port variable switch
- (6) AUX hold switch (Left)
- (7) AUX hold switch (Right)
- (8) Float Switch
- (9) Hydraulic quick-hitch switch (Hydraulic quick-hitch model only)
- (10) Starter switch
- (11) Hydraulic unlock switch
- (12) Parking brake switch
- (13) AUX port switch
- (14) Working light switch
- (15) Wiper / washer switch (Closed cab model)
- (16) Inhibit Switch

## ■ Control Pedals, Levers and Electrical Outlet

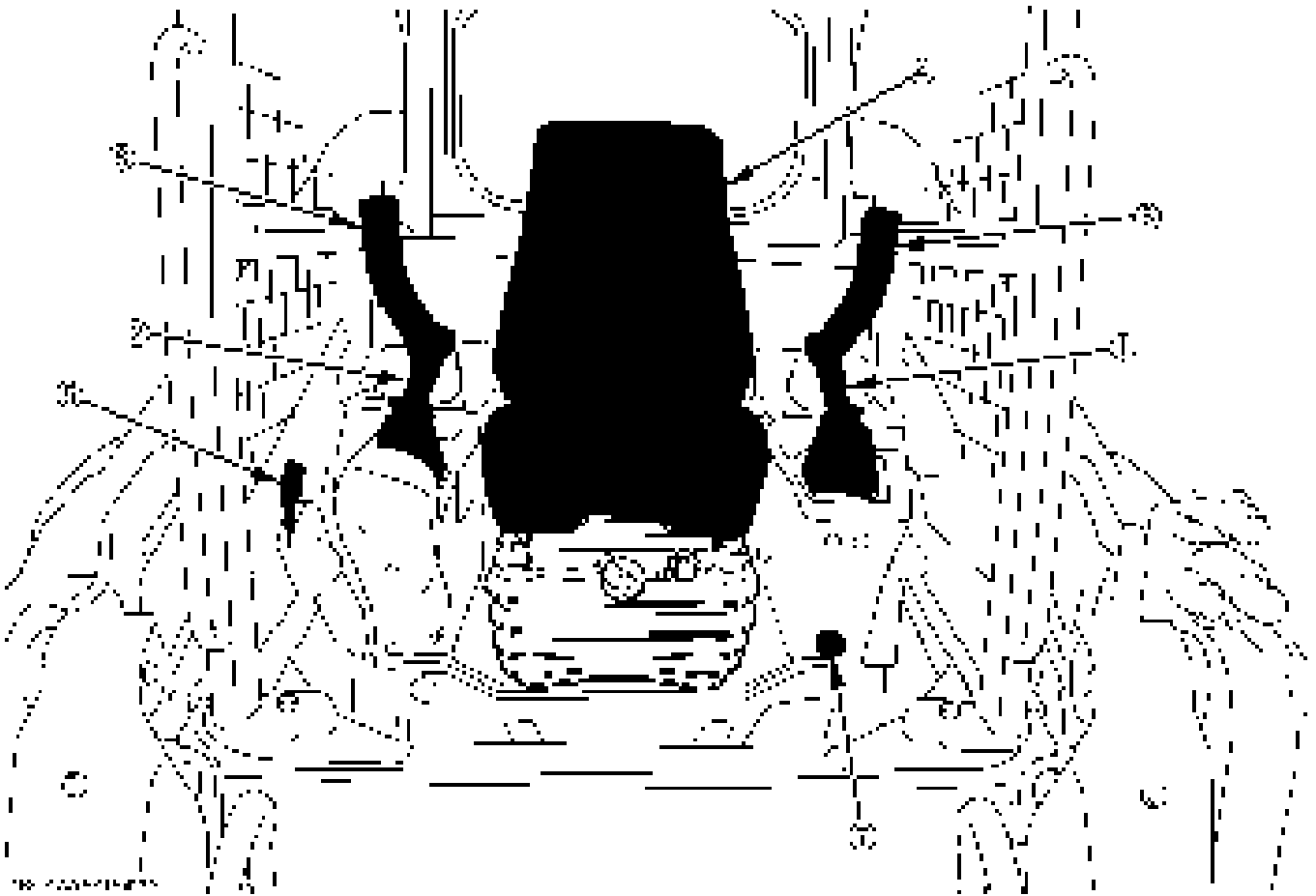

### DEPICTED CONTENTS

- (1) Left control (traveling) lever
- (2) Right control (front operating) lever
- (3) Armrest
- (4) Seat
- (5) Accelerator lever
- (6) Accelerator pedal
- (7) Electrical outlet

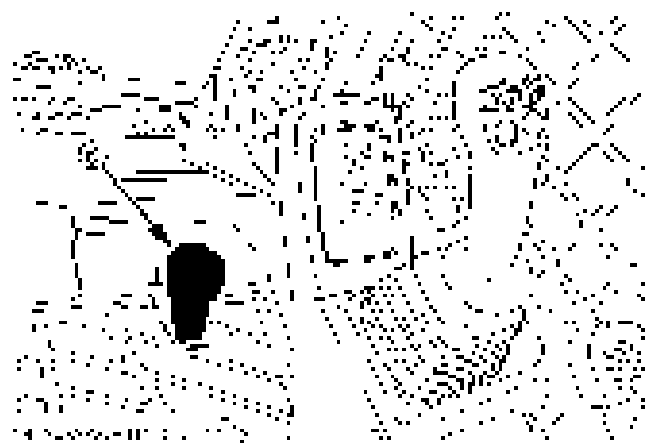

■ Instrument Panel

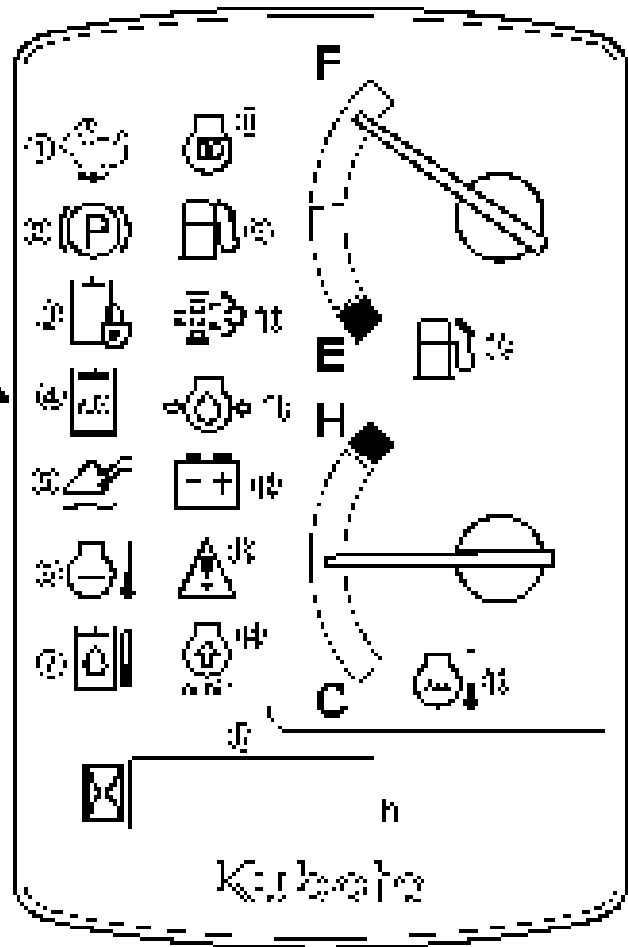
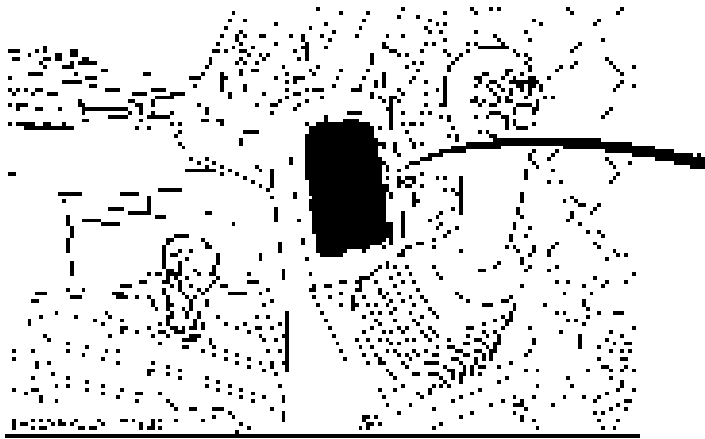

INSTRUMENT PANEL

DEPICTED CONTENTS

- |  |                                       |
|--|---------------------------------------|
| (1) Speed indicator lamp                   | (10) DPF regeneration indicator       |
| (2) Parking brake lamp                     | (11) Engine oil pressure warning lamp |
| (3) Hydraulic lock lamp                    | (12) Battery charge lamp              |
| (4) AUX operation lamp                     | (13) Warning lamp                     |
| (5) Floating lamp                          | (14) Engine rev up warning lamp       |
| (6) Coolant temperature warning lamp       | (15) Fuel gauge indicator             |
| (7) Hydraulic oil temperature warning lamp | (16) Coolant temperature gauge        |
| (8) Glow lamp                              | (17) Hour meter & Error code number   |
| (9) Remaining fuel warning lamp            |                                       |

NOTE :

- Error code indicates and number. (For detail, refer to "List of Error Code Numbers" in "TROUBLESHOOTING" section.)

# CHECKS BEFORE START

## DAILY CHECKS

In order to avoid damage, it is important to check the condition of the machine before starting.



### CAUTION

To avoid personal injury:

- Do maintenance work on the machine only on level ground with the engine off and armrest in the "Raised" position.

### Checks

- Go around the machine and check for visual damage and wear.
- Check coolant level. (See "DAILY CHECKS" in "MAINTENANCE" section.)
- Check fuel level.
- Check engine oil level.
- Check hydraulic fluid level.
- Check dust indicator of air cleaner. (See "DAILY CHECKS" in "MAINTENANCE" section.)
- Check all control lamps, indicators and hour meter.
- Check the light system.
- Check the seat belt and the ROPS/FOPS safety device.
- Check Diesel Particulate Filter (DPF) muffler
- Check the condition of the safety and warning labels. (See "DANGER, WARNING AND CAUTION LABELS" in "SAFE OPERATION" section.)

## CHECKING THE SWITCHES

### ■ Hydraulic Unlock Switch

The hydraulic unlock switch enables the hydraulic system. The switch is intended to get the hydraulic system (travelling and attachments) ready for use, but does not have the locking function.

To unlock the hydraulic system, the following requirements are needed:

- (1) The engine is running.
- (2) The armrests are down.
- (3) The operator is seated on the operator's seat.

When the hydraulic system has been unlocked, the hydraulic lock lamp on the instrument panel disappears.

If any of the above conditions is not met, the hydraulic system stays locked.

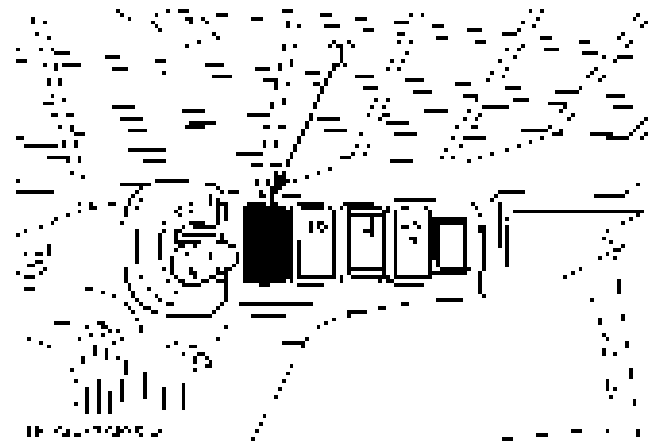

(1) Hydraulic unlock switch

### ■ OPC Switch

This switch is used to detect the operator sitting on the seat and to signal the hydraulic system that it can be locked and unlocked.

When the operator sits on the seat, the OPC switch is ON, the hydraulic system can be unlocked.

When the hydraulic system is unlocked and the operator leaves the seat for up to 3 seconds, the OPC switch turns off. Now the hydraulic system is locked.

## ■ Parking Brake Switch



### WARNING

To avoid personal injury or death:

- When dismantling the machine or when servicing or hauling, be sure to apply the parking brake.

The parking brake is to be used when parking the machine.

1. When the parking brake switch is pressed on "P" marked side (the right side), the parking brake is applied and the "P" mark on the instrument panel appears.
2. When the switch is pressed on the left side, the parking brake is released and the "P" mark on the instrument panel lights off.

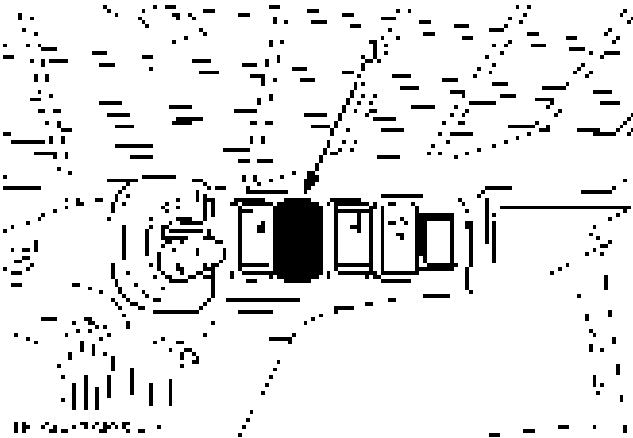

(1) Parking brake switch

### NOTE :

- Suppose that the parking brake switch is ON ("P" marked side depressed). Even if the hydraulic system gets unlocked, the travel system remains out of service and the brakes are still applied. When the hydraulic system has been locked, the travel system gets locked too, and the brakes can get on.

## ■ AUX Port Switch

This switch is used to enable the AUX port.

Press the switch once, and the AUX port is unlocked and the "AUX" mark on the instrument panel lights up. By pressing the switch again, the AUX port now gets locked. The AUX port switch can be used only when the AUX port variable switch on the right control lever is in the neutral position.

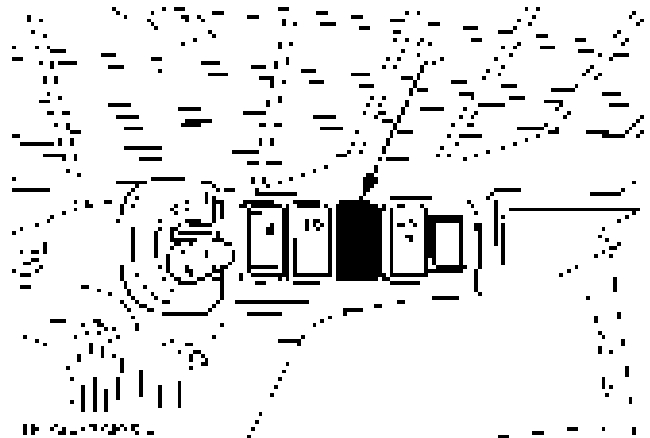

(1) AUX port switch

## ■ Inhibit Diesel Particulate Filter (DPF) Regeneration Switch

Inhibit Diesel Particulate Filter (DPF) regeneration switch (hereinafter called inhibit switch) disables the Auto DPF regeneration cycle. Activate this switch to turn "off" Auto DPF Regeneration when working around people, animals, plants, and flammable materials. Certain work conditions may require the Auto DPF regeneration cycle to be disabled. Depress the switch once to turn off Automatic mode. Depress the switch once again to return from disable to Automatic mode.

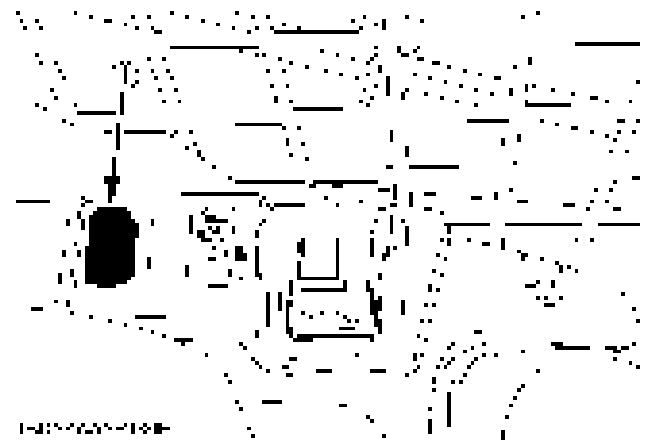

(1) Inhibit Switch

### ■ Working Light Switch

This switch is operative with the starter key in the ON position.

The switch has 3 positions. When positioned on your side, the lights stay off. Move the switch to the first position to turn on the front working light, and to the second position to turn on both the front working lights and rear working lights.

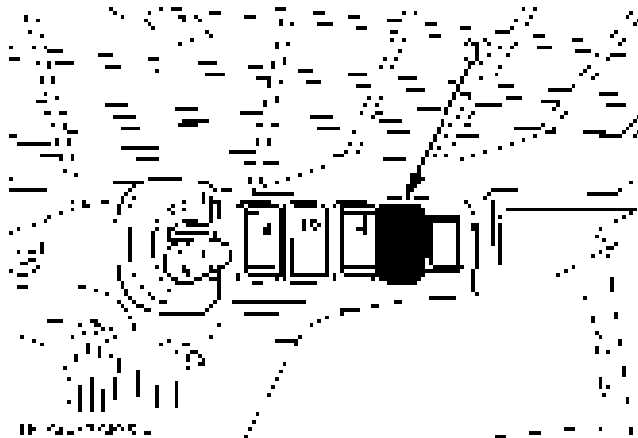

(1) Working light switch

### ■ Interior Lamp Switch

The interior lamp is operative even when the starter key is in the "STOP" position.

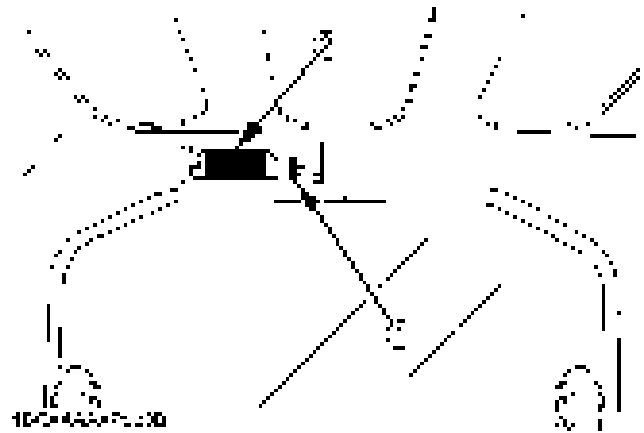

(1) Interior lamp switch  
(2) Interior lamp

### ◆ Night operation



### CAUTION



To avoid personal injury:

- Visibility is reduced in darkness, therefore, in the event, the working light alone does not provide sufficient visibility. Prepare additional stationary artificial lighting, observe all safety rules and any special regulations for night work.

### ■ Travel Speed Switch

Travel speed will increase when this switch is pressed down.

Switching the dual travel speed:

1. Press the travel speed switch. The buzzer beeps twice and the travel speed changes from low to high speed. The  symbol lights up.
2. Press the travel speed switch again, and the buzzer beeps once and the travel speed changes from high to low speed. The  symbol goes out.

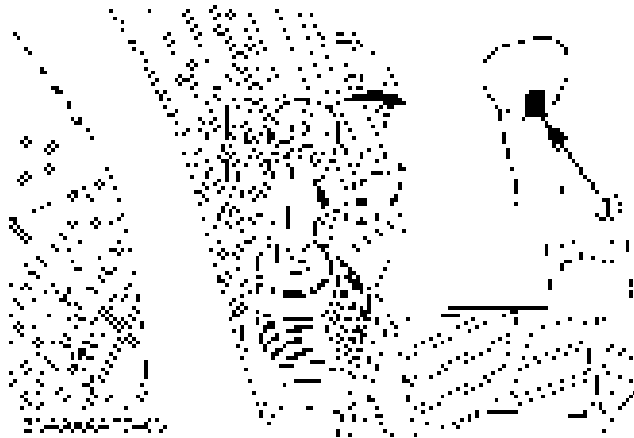

- (1) Travel speed switch  
(2) Speed indicator light

#### NOTE :

- When activating the travel speed switch, it must be pressed completely. (The switch is operative only when the travel system is unlocked)
- Each time the travel speed switch is pressed, the travel speed is switched between high and low speed.

### ■ Horn Switch

Even when the starter key is in "STOP" position, the horn will be beeped by pressing the horn switch.

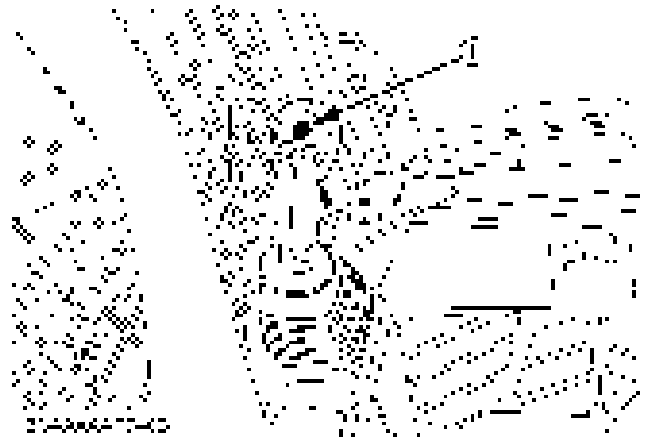

- (1) Horn switch

### ■ AUX Port Variable Switch

With the AUX port unlocked, the hydraulic oil flow rate varies depending on the tilt angle of the switch.

Right-hand control:

The flow rate through the right-hand port (male) varies.

Left-hand control:

The flow rate through the left-hand port (female) varies.

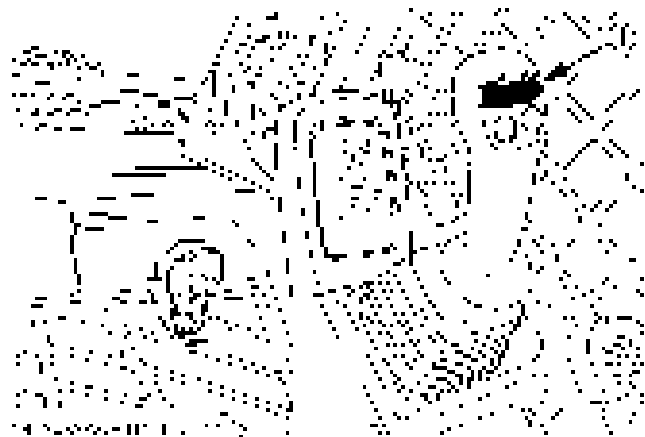

- (1) AUX port variable switch

## ■ AUX Hold Switch

Press the right or left hold switch to maximize the flow rate.

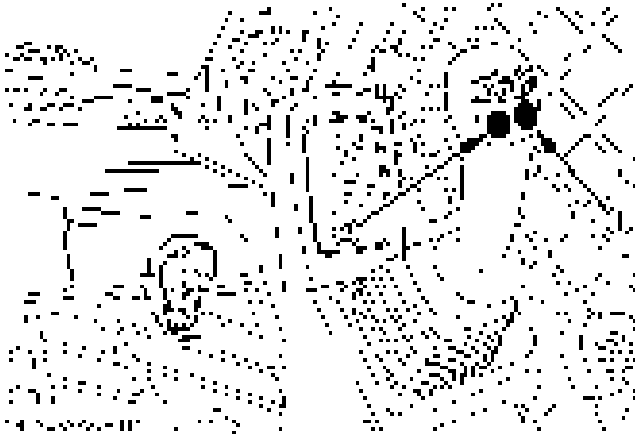

(1) AUX hold switch (Right)  
(2) AUX hold switch (Left)

## ■ AUX Electrical Control Switch (Option)

With the AUX port switch unlocked, this switch serves to feed electrical power to attachments.

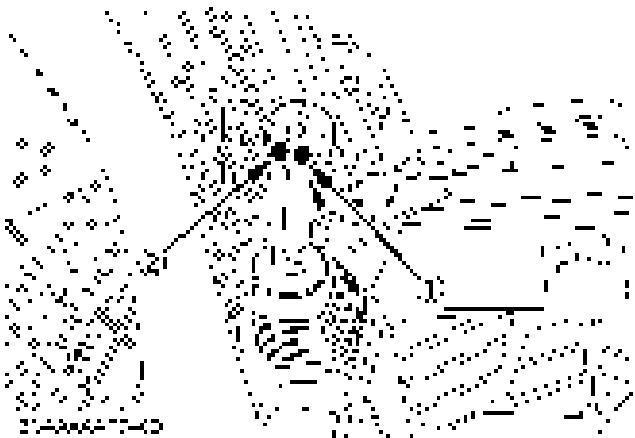

(1) AUX electrical control switch (Right)  
(2) AUX electrical control switch (Left)

### NOTE :

- The 14-pin coupler (option) is required for this function.

## ■ Float Switch



### WARNING

To avoid personal injury or death:

- Make sure the bucket is lowered to the ground before putting the lift arms in the "FLOAT" position. Putting the lift arms in the "FLOAT" position while they are off the ground will cause the bucket and lift arms to fall and is extremely dangerous.
- Do not drive the machine forward with the lift arms in the "FLOAT" position.

### ◆ Entering the float mode

While moving down the arm (tilting the right control lever forward), press the float switch on the right control lever and release it no later than 1 second. The float mode is then turned on.

While in the float mode, the "☞" mark on the instrument panel stays on.

### ◆ Exiting the float mode

While the machine is in the float mode,

- (1) Press the float switch on the right control lever.
- (2) Or move up the arm (pulling the right control lever backward).

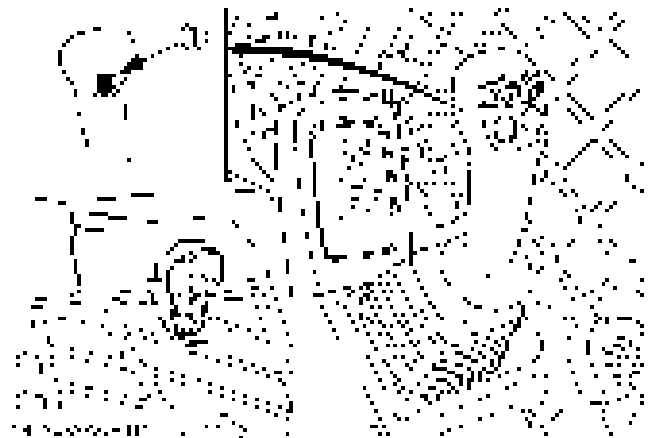

(1) Float switch

## ■ Starter Switch

- **[STOP]**  
The key can be inserted at the "STOP" position.
- **[RUN]**  
Turn the key one click from the "STOP" position to the "RUN" position. All the circuitry gets energized to start preheating. The glow indicator is displayed.  
To check for any lamp breakage, however, the lamp lights up and stays on for about 1 second.
- **[START]**  
Turn the key from the "RUN" position another click to the "START" position. The starter motor is then activated to get the engine started.  
Release your hand from the key, and the key returns itself to the "RUN" position. In other words, once the engine has started, be sure to free the key.



(1) Starter switch

(A) "STOP"  
(B) "RUN"  
(C) "START"

## ■ Hydraulic Quick Switch (Hydraulic Quick-Hitch model only)



### WARNING

To avoid personal injury or death:

- Make sure to close the cover when not activating the hydraulic quick-hitch.

The switch is used to attach and detach an attachment by activating the hydraulic quick-hitch.

Move the switch to the "🔒" (LOCK) mark to get the hitch locked. Move it to the "🔓" (UNLOCK) marked position to unlock the hitch and detach the bucket, for example. After cylinder is moved to locked position, always check to be sure both pins are engaged to the attachment.

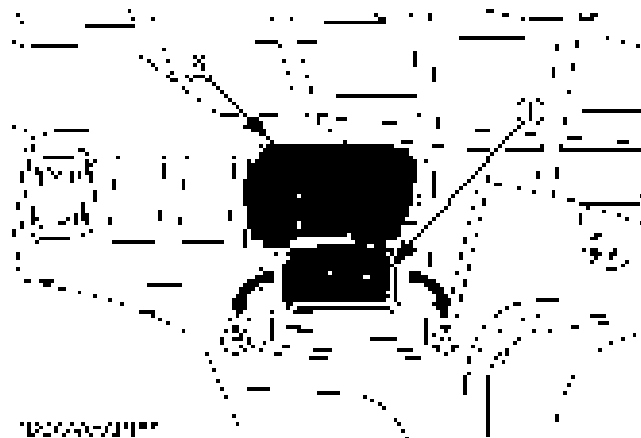

(1) Hydraulic quick-hitch switch  
(2) Cover

(A) "UNLOCK" position  
(B) "LOCK" position

## ■ Wiper/Washer Switch (Closed cab model)

To start the wiper, move the switch to the "A" position when the starter key is in "RUN" position. A further push on side "A" of the switch will also activate the washer system.

Move the switch to the "B" position to spray cleaning fluid to the pane.

- Do not activate the washer switch (B) if the tank for the cleaning fluid is empty; the pump can be damaged.
- Do not activate the wiper switch (A) if the window is dry. In this case, make sure that cleaning fluid is applied to the pane before activating the wiper.
- In freezing conditions, make sure that the wiper blade is not frozen to the glass before switching-on. The motor can be damaged if the wiper system is used under such conditions.

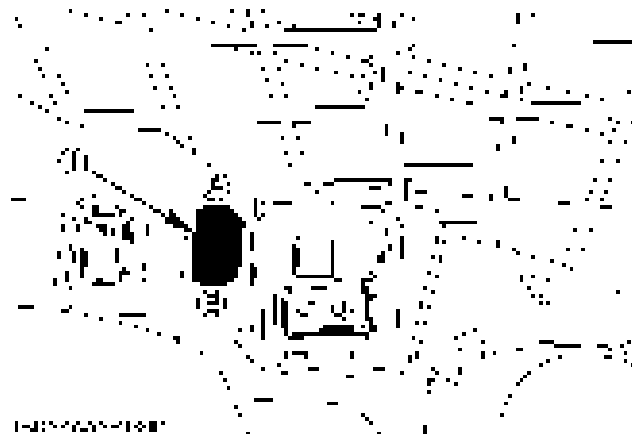

(1) Wiper / Washer switch

(A) "Wiper"  
(B) "Washer"

### NOTE :

- Wiper and washer are operable only during engine operation.

## CHECKING THE LAMPS AND INDICATORS

### ■ Fuel Gauge Indicator



#### CAUTION

To avoid personal injury:

- Before adding fuel, be sure to stop the engine.
- Be sure to keep open flame away from the machine. Otherwise a fire may result.

With the starter key at the "RUN" position, the fuel remaining in the fuel tank is indicated in the indicator.

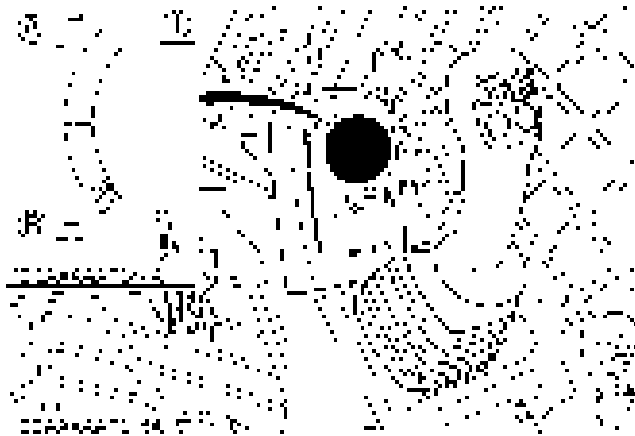

(1) Fuel gauge indicator

(A) "FULL"  
(B) "EMPTY"

If the fuel runs short, open the cap and refuel the tank.

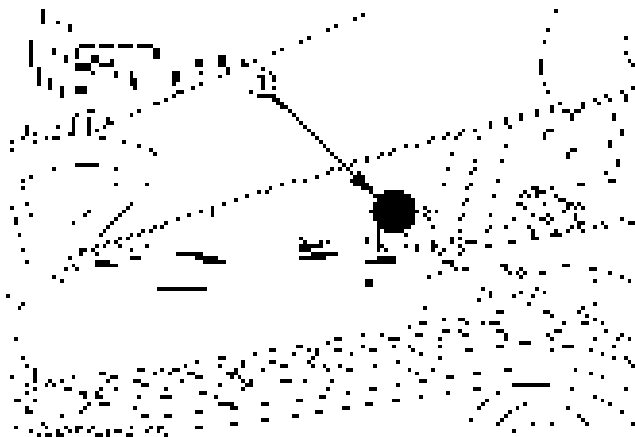

(1) Cap

#### IMPORTANT :

- If the fuel gauge indicator is near the "E", add fuel as soon as possible. If the indicator is near "E" and the machine runs on a slope, the engine may run out of fuel and get interrupted.
- Be very attentive to the remaining fuel for the engine not to stall. If the engine stalls, it may fail to get restarted for a while to protect the emission purifying device.

#### NOTE :

- To open the fuel cap, keep the starter key inserted.

### ■ Remaining Fuel Warning Lamp

If the fuel in the tank goes below the prescribed level, the warning lamp will flash.

If this should happen during operation, refuel as soon as possible.

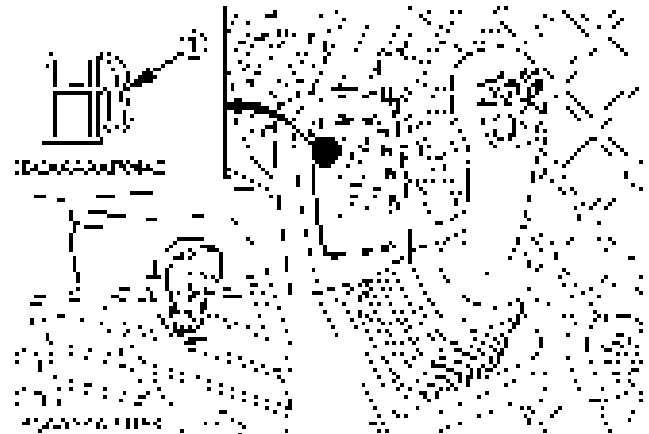

(1) Remaining fuel warning lamp

**■Coolant Temperature Gauge**

**⚠ CAUTION**

To avoid personal injury:

- Do not open the radiator cap during or just after operation. Hot water may gush out and scald you. Wait for the water to cool down before opening the cap.

With the starter key at the "RUN" position, the coolant temperature is indicated.

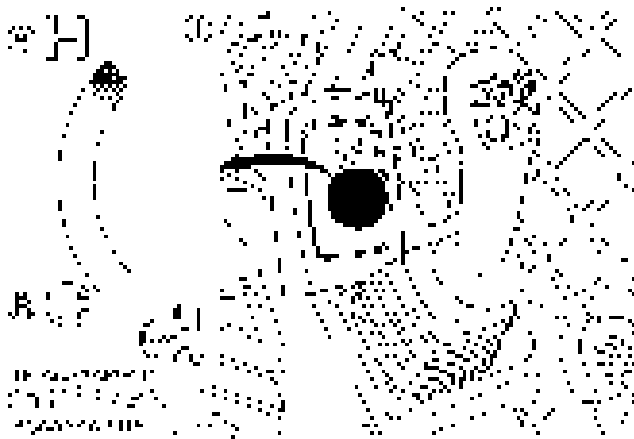

(1) Coolant temperature gauge (A) "HOT" (B) "COOL"

If engine coolant rises above a specified temperature level, the indicator starts blinking and the buzzer starts beeping every 6 minutes for advance warning. If the coolant temperature further rises to the critical level, the blinking intervals become shorter and the buzzer keeps on beeping.

When the coolant temperature has dropped below specified temperature level or the starter key has been moved to the "STOP" position, the warning will cease.

If the coolant temperature gauge is near "H", take the steps below.

1. Discontinue the job.
2. Reduce engine rpm's to idle and keep it at idle for 5 minutes.
3. Stop the engine and check the following points (1)-(4).
  - (1) Low coolant level or leak
  - (2) V-belt tension
  - (3) Mud, dust or chaff deposits blocking the radiator or screen
  - (4) Hydraulic oil leak

**IMPORTANT :**

- If the emission alarm (E: 9114 or 9115) is displayed, the EGR valve will begin to close and EGR system will not function. Interrupt the work and lower the engine rpm, which will reduce the coolant temperature.

**■Parking Lamp**

When the parking brake switch is turned on, the parking lamp on the instrument panel turns on. (See page 8.)

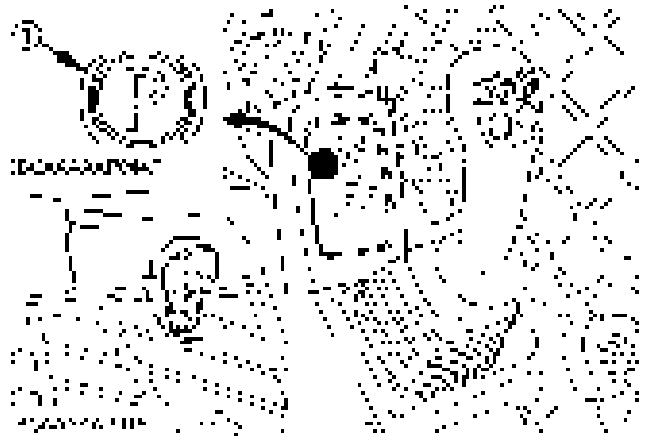

(1) Parking lamp

**■Floating Lamp**

While in the float mode, the "⚠" mark on the instrument panel stays on.

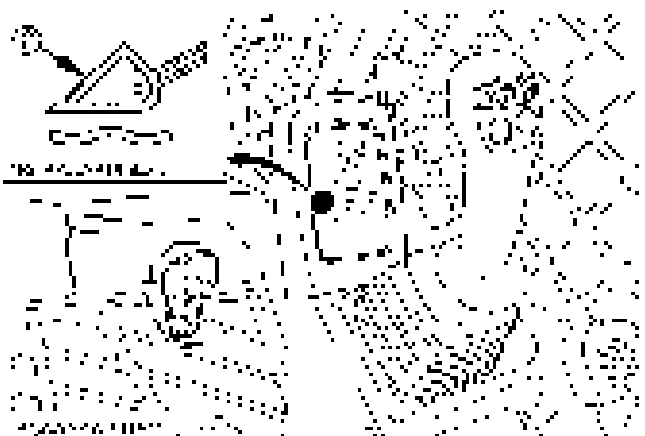
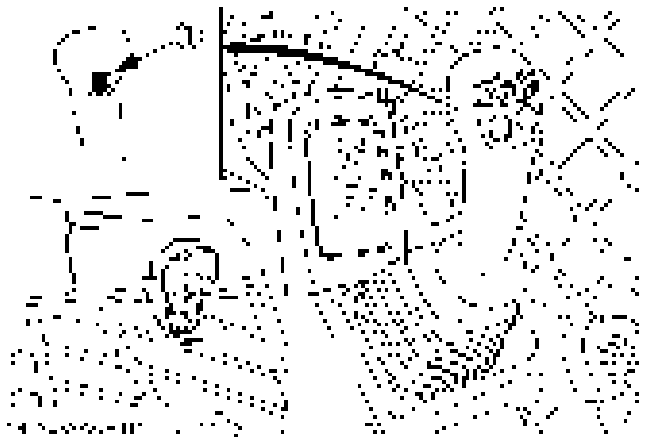

(1) Float switch (2) Floating lamp

### ■ Warning Lamp

The warning lamp is used to indicate broken wire, short-circuit and other problems.

The lamp lights up to warn you of a detection of broken or short-circuited hydraulic lock/unlock solenoid, AUX port variable switch and other elements.

#### IMPORTANT :

- If the warning lamp lights up, consult your local KUBOTA dealer immediately.

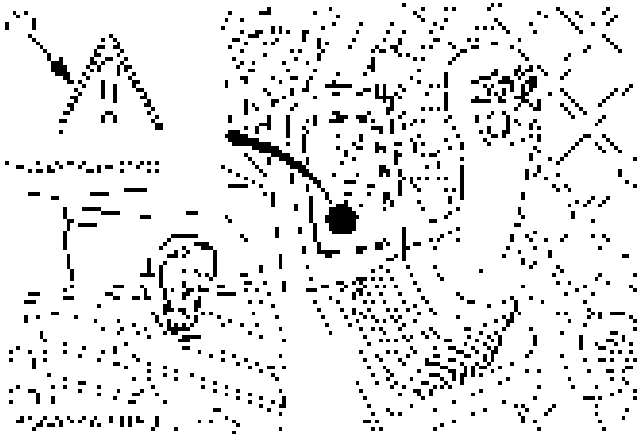

(1) Warning lamp

### ■ Glow Lamp

The glow lamp is displayed when the starter key is turned to the "RUN" position but the engine requires preheating. Wait until the indicator goes out, and then start the engine.

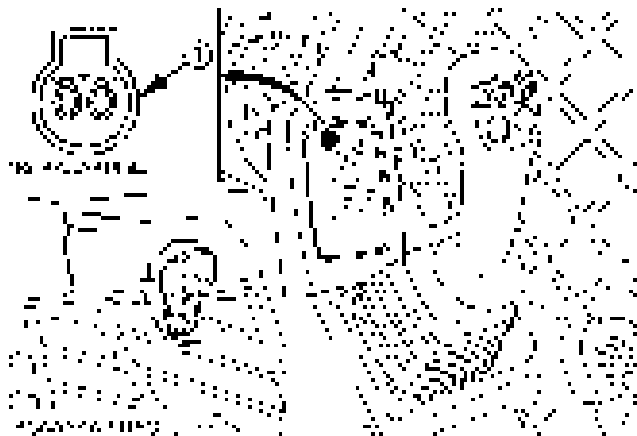

(1) Glow lamp

### ■ Engine Oil Pressure Warning Lamp

The engine oil pressure warning lamp lights up due to failure of the lubricating system with the engine running.

When the starter key is turned in "RUN" position with the engine off, this lamp lights up and when the engine starts, the lamp goes out.

If the lamp stays on with the engine running, stop the engine and check the engine oil level.

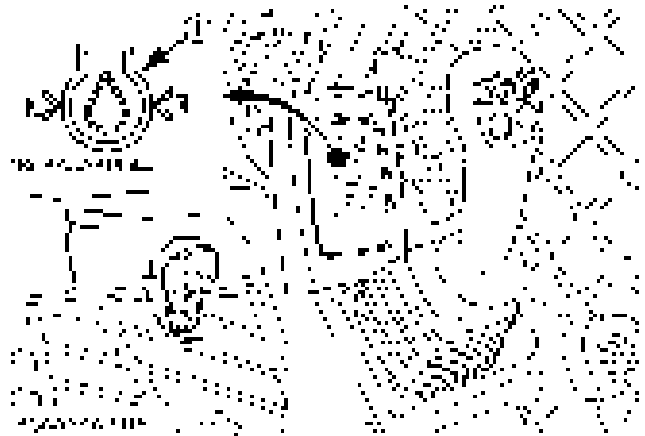

(1) Engine oil pressure lamp

### ■ Battery Charge Lamp

This battery charge lamp lights up if the charging system fails the engine running.

When the starter key is turned in "RUN" position with the engine off, the lamp lights up and when the engine starts, the lamp goes out.

If the lamp stays on with the engine running, stop the engine and check the V-belt.

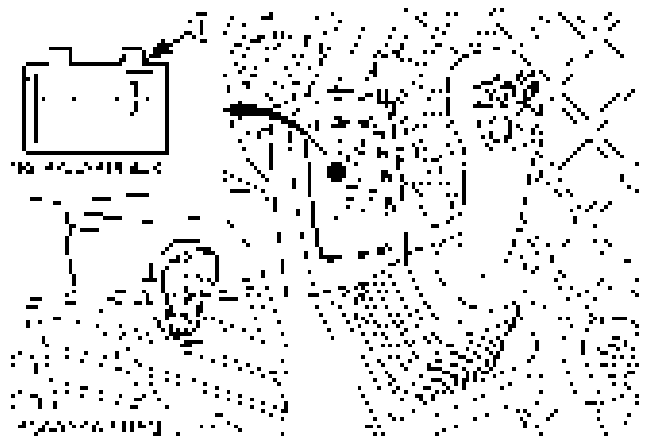

(1) Battery charge lamp

### ■ Hydraulic Oil Temperature Gauge

The lamp starts blinking and the buzzer starts beeping if the hydraulic oil temperature has reached a specified level.

When the oil temperature has dropped below the specified level or the starter key is turned off, the warning will cease.

Stop the engine and check for an unspecified level in the hydraulic oil tank and for a hydraulic oil leak.

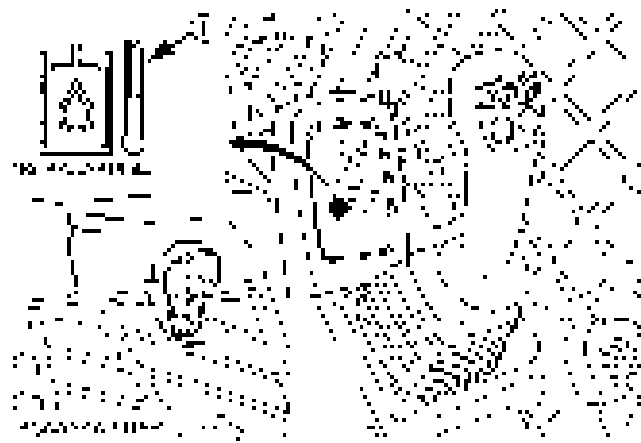

(1) Hydraulic oil temperature warning lamp

### ■ Hour-Meter

Indicates the total operating hours of the machine.

How the indicator works

- The meter advances one hour after an hour of operation regardless of the engine rpm.

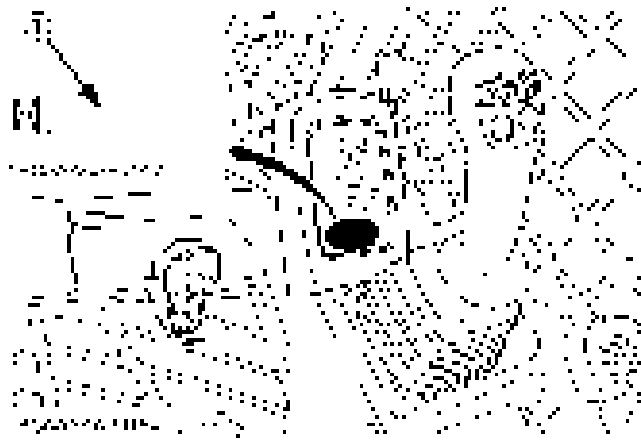

(1) Hour-meter

### ■ Diesel Particulate Filter (DPF) regeneration indicator

As PM (Particulate Matter) build up inside the DPF, the DPF regeneration cycle starts automatically to burn away PM. During DPF regeneration, this lamp lights up and stays on and the beep tone keeps sounding to warn the operator.

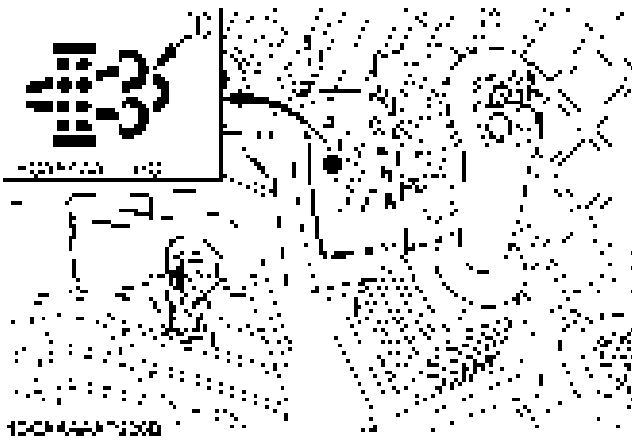

(1) DPF regeneration indicator

### ■ Engine rev up warning lamp

If the engine rpm is too low to start regeneration, the DPF regeneration indicator lights up and starts blinking. In such case, rev up the engine until this lamp goes out, the regeneration will automatically start.

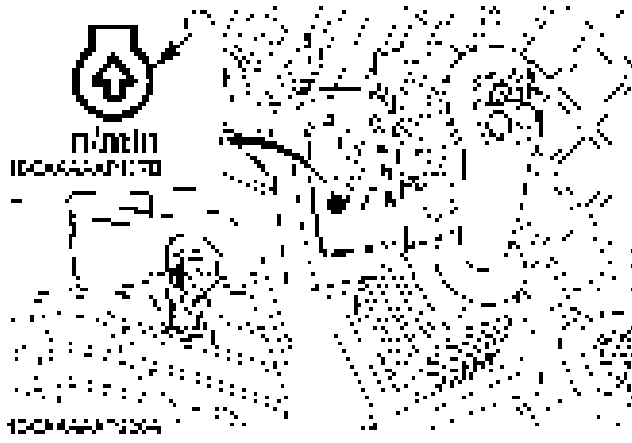

(1) Engine rev up warning lamp

## EXHAUST AFTERTREATMENT DEVICES

### ■ Catalyst-containing Diesel Particulate Filter (DPF) device

This after-treatment device has two functions: reducing certain emissions, like hydrocarbon (HC) and carbon monoxide (CO), to innocuous carbon dioxide and water, and trapping and elimination PM (Particulate Matter) through the filter at the same time.

Following EPA regulations, it is necessary to service the DPF, such as renewing or cleaning the filter at regular intervals.

Be sure to carefully read this Operator's Manual before using the machine. The machine owner and operator are responsible for handling this device correctly to protect the environment and to prevent damage to the DPF, and comply with Federal and state regulations.

#### ◆ Handling instructions

##### ● Fuel

Be sure to use ULTRA LOW SULFUR FUEL (S15).

Use of other diesel fuel other than this may adversely affect the engine and the emission control device and may damage them.

##### ● Engine oil

Use DPF-compatible engine oil (CJ-4). Any unspecified oil may damage the DPF earlier than expected and lower fuel economy.

#### IMPORTANT :

- If you use different fuel or engine oil, the cleaning interval of the DPF (3000 hours) can't be secured and the DPF will be clogged for a shorter time than expected.

#### ◆ Prohibited unnecessary idling

Generally speaking, the lower the engine rpm is, the lower the exhaust gas temperature is. It is more difficult to burn PM (Particulate Matter) in the DPF. With this in mind, do not keep the engine idling unnecessarily.

If you leave the machine with the engine running, to protect the DPF the engine can stop automatically.

#### ◆ DPF regeneration system

On the Kubota CTL, the ECU prompts DPF-regeneration cycle. When starting the engine, Auto Regeneration Mode is set by default. When all the conditions are met, regeneration automatically starts, unless the inhibit switch is engaged.

### ■ Regeneration of Diesel Particulate Filter (DPF)



#### CAUTION

To avoid personal injury:

- When the DPF is in the regenerating mode, the exhaust gas and the DPF muffler become hot. During the regeneration, take into account that the muffler will be very hot and keep the machine away from other people, animals, plants, and flammable material. Also keep the area near the DPF muffler clean and away from flammable material.
- Do not leave the machine during DPF regeneration.

The DPF level of PM during operation is indicated by indicator symbol and buzzer.

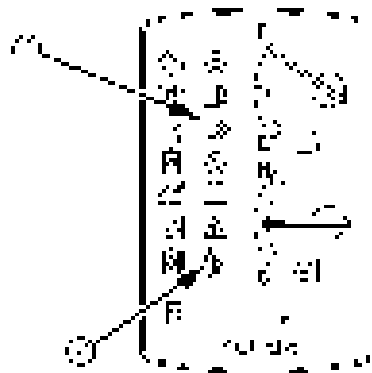

INSTRUMENT.

- (1) DPF regeneration indicator
- (2) Engine rev up warning lamp

#### NOTE :

- During DPF regeneration cycle keep clear of the surrounding environment in mind. Do not allow the ambient temperature to rise excessively due to heat from the regeneration. If such occurs, activate the inhibit switch.
- The DPF regeneration cycle only starts in the following conditions. If any of the conditions are not met, the DPF regeneration cycle may be interrupted.
  - (1) Coolant temperature above 65°C
  - (2) DPF temperature above 250°C
  - (3) Engine rpm above 1200 rpm
- The regeneration usually takes about 15-20 minutes. It depends, however, on the outside air temperature, exhaust gas temperature and filter PM level.
- Do not attempt to interrupt the DPF regeneration cycle unnecessarily.

## CHECKING THE SAFETY DEVICES



### WARNING

To avoid personal injury or death:

- Place the machine on a firm, flat and level surface.
- Before starting the engine, make sure that no one is near the machine.

### Emergency Exit

If you should become trapped in the cab, you can remove the rear window to get out.

1. The rear window in the machine serves as the primary alternate exit.
2. The window will need to be removed in order to use the primary alternate exit.
3. Pull on the ring at the top of the window in order to remove the window.
4. The ring will remove the seal that holds the window in place.
5. When the seal is taken out, remove the window and exit the cab.

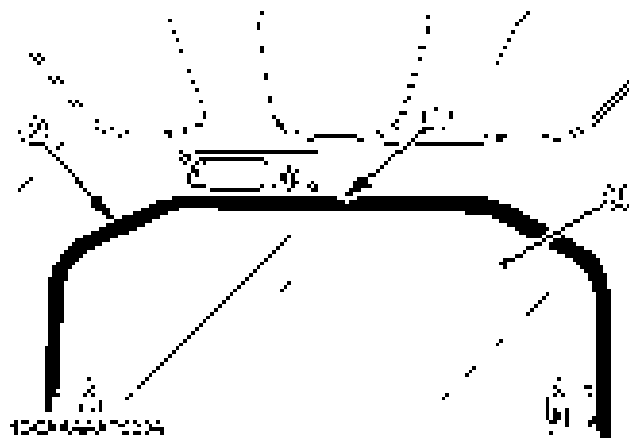

- (1) Ring
- (2) Seal
- (3) Window

### Armrests Function

1. Sit in the operator's seat.
2. Fasten the seat belt.
3. Start the engine.
4. Push down both the armrests.
5. Push on the hydraulic unlock switch and make sure that the hydraulic lock lamp on the instrument panel goes out.
6. Move the right control (front operating) lever slowly and make sure that the lift arms and bucket move slowly.
7. Raise the left armrest. Make sure that the hydraulic lock lamp on the instrument panel lights up.
8. Move the right control (front operating) lever and make sure that the lift arms and bucket do not get activated.
9. Push down the left armrest.
10. Push on the hydraulic unlock switch and make sure that the hydraulic lock lamp on the instrument panel goes out.
11. Raise the right armrest. Make sure that the hydraulic lock lamp on the instrument panel lights up.
12. Move the right control (front operating) lever and make sure that the lift arms and bucket do not get activated.

### OPC Function



### WARNING

To avoid personal injury or death :

- While checking the OPC function, you start the engine without wearing the seat belt. After making sure that the OPC function gets activated as specified, be sure to fasten the seat belt and operate the machine.

Make sure that the armrests function as specified, and then check the OPC function.

1. Sit in the operator's seat.
2. Start the engine.
3. Push down both the armrests.
4. Push on the hydraulic unlock switch and make sure that the hydraulic lock lamp on the instrument panel goes out.
5. With the armrests kept down, get off the operator's seat and make sure that the hydraulic lock lamp on the instrument panel lights up in 3 seconds. During this action, be careful not to touch the right control (front operating) lever and the left control (travel operating) lever.

## ■ Forced Lift Arms Lowering Device

1. Start the engine.
2. Move the right control (front operating) lever until the lift arms come up to your eye level.
3. Stop the engine.
4. Slide the operator's seat all the way backward.
5. Remove the rubber cap.
6. Push the lever to make sure that the lift arms descend.
7. Release the lever to make sure that the lift arms stop descending.
8. Place the rubber cap back to its original position.



(1) Rubber cap  
(2) Lever

(A) "PUSH"

## DOOR AND WINDOWS

### ■ Opening/Closing of Cab Door (Closed cab model)



#### CAUTION

To avoid personal injury:

- Keep hands and feet away from the area between cab door and cab frame. Otherwise the operator risks serious injuries by pinching or crushing.
- Other persons should stay away when opening the cab door.

#### ◆ To open the cab door from outside, follow the steps below.

1. Unlock the cab door and push the button. The cab door will open upward.
2. Push the cab door all the way up until it locks to the top of the cab.



(1) Button

3. After opening, lock in place by moving both lock pins to outside to prevent door from inadvertently falling.

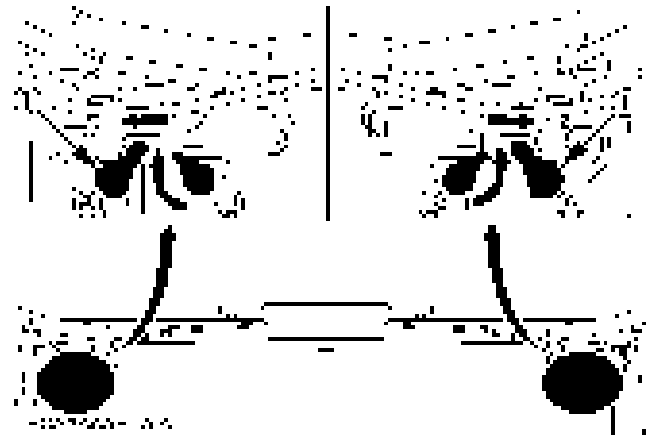

(1) Lock pin

(A) "LOCK"  
(B) "UNLOCK"

◆ To close the cab door from outside, follow the steps below.

1. Before closing, unlock in place by moving both lock pins to inside.
2. Push the lock lever at the bottom of the cab door and slowly lower the cab door half way.
3. Grasp the top handle and pull it toward yourself to latch the cab door.

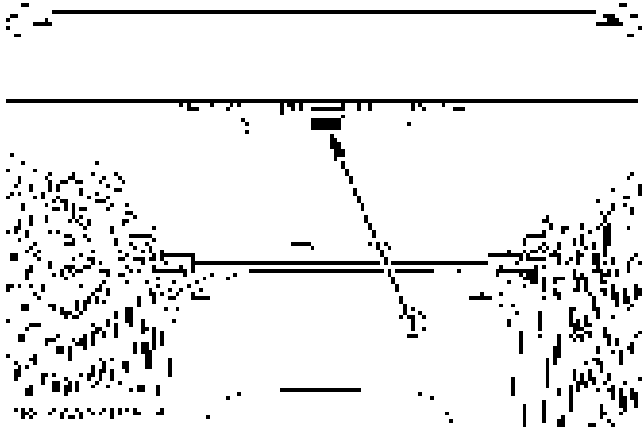

(1) Lock lever (bottom)



(1) Top handle

4. When leaving the machine, always lock the cab door.

◆ To open the cab door from inside, follow the steps below.

1. Hold the handles tightly with both hands and push the lock levers beside the handles.



(1) Handle  
(2) Lock lever

2. Pull the handles slightly upward and toward yourself to let the cab door slide inward.
3. Pull the cab door all the way to the lock at the back of cab.

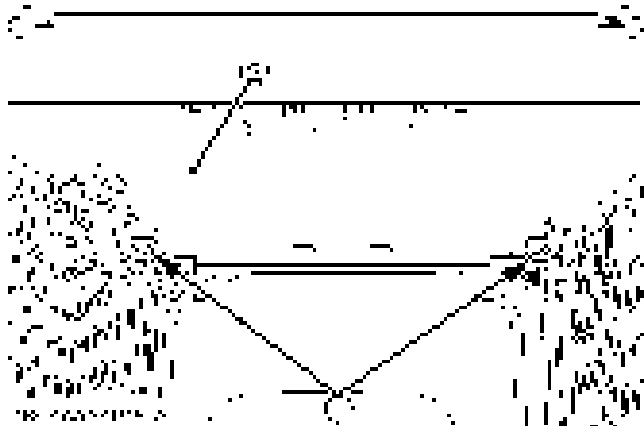

(1) Handle  
(2) Cab door

- After opening, lock in place by moving both lock pins to outside to prevent door from inadvertently falling.

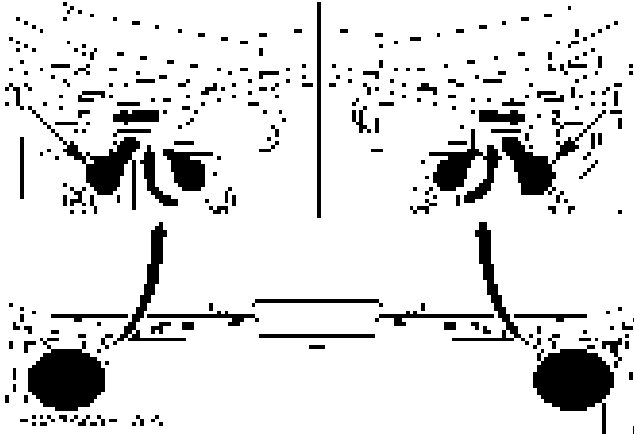

(1) Lock pin

(A) "LOCK"  
(B) "UNLOCK"

- ◆ To close the cab door from inside, follow the steps below.

- Before closing, unlock in place by moving both lock pins to inside.
- Hold the handles tightly with both hands. Push the lock levers beside the handles.
- Pull the handles down and forward to move the cab door from the horizontal to the vertical position.
- Push the cab door until it latches in the door opening.



## CAUTION

To avoid personal injury :

- Do not use the lock lever at the bottom of the cab door from inside.
- Use caution and both hands to open/close the cab door to avoid contact with your head.



(1) Lock lever (bottom)

## ■ Opening/Closing of Side Cab Window (Closed cab model)

- Pull the grip to release the lock and pull side window open to the rear or to the front.
- To close the side window, slide it forward or backward until the lock snaps in at the window frame.

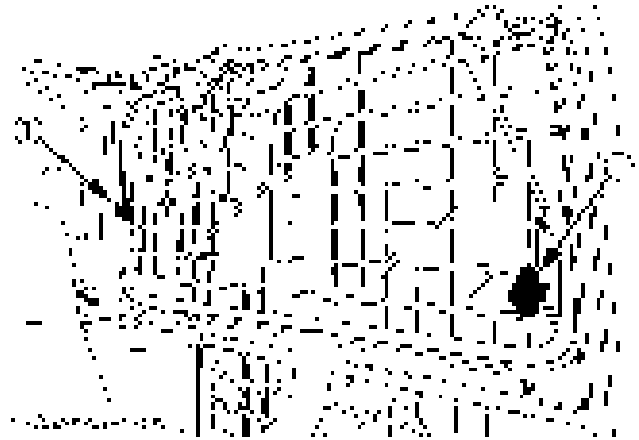

(1) Grip

## AIR-CONDITIONER

### ■ Air Flow

Air flow in the cab and fresh air flow into the cab flow is shown in the below figure. Adjust the six air outlet ports to obtain the desired air flow.

[Front air outlet port]

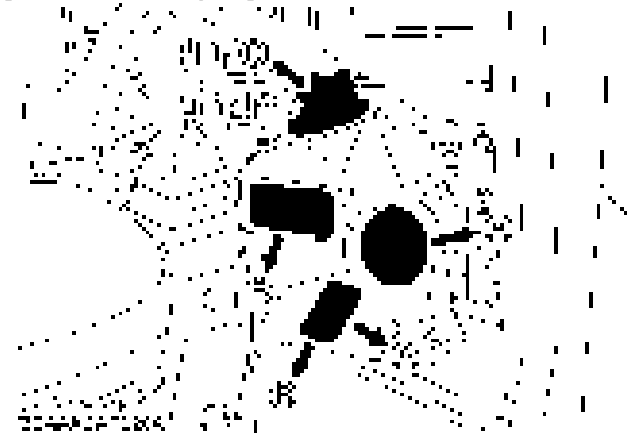

(A) "WINDSHIELD"  
(B) "FOOT AREA"  
(C) "CHEST AREA"

**[Rear air outlet port (for cool air only)]**



(A) "CHEST AREA"  
(B) "WINDSHIELD"

Position the inlet selector knob to the desired position.

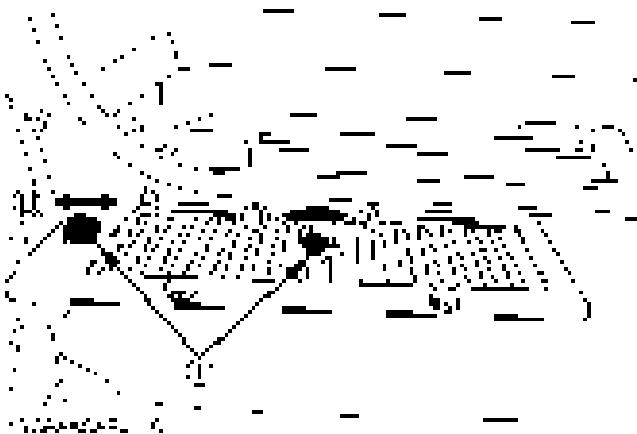

(1) Inlet selector knob (A) "FRESH AIR INLET" position  
(B) "INSIDE AIR RECIRCULATION" position



(C) "FRESH AIR INLET"

**IMPORTANT :**

- Do not allow water to enter the fresh air inlet when washing the machine.

**NOTE :**

- The rear air outlet port is for cool air only. No warm air is blown out from here.
- When heating, do not keep the inlet selector knob at the "INSIDE AIR RECIRCULATION" position for a long time. The windshield easily gets foggy.
- To raise the air flow rate from the outlet ports, set the inlet selector knob to the "INSIDE AIR RECIRCULATION" position.
- While working in a dusty condition, keep the inlet selector knob at the "FRESH AIR INLET" position. This increases the pressure in the cab, which helps prevent dust from coming into the cab.

**■ Air Control Vent**

**◆ Air outlet**

The air outlet ports can be independently adjusted as required.

To defrost the windshield, set the inlet selector knob to the "FRESH AIR INLET" position and rotate the air outlet ports toward the windshield.

**[Front air outlet port]**



(A) "WINDSHIELD"  
(B) "FOOT AREA"  
(C) "CHEST AREA"  
(D) "CLOSED"

[Rear air outlet port (for cool air only)]

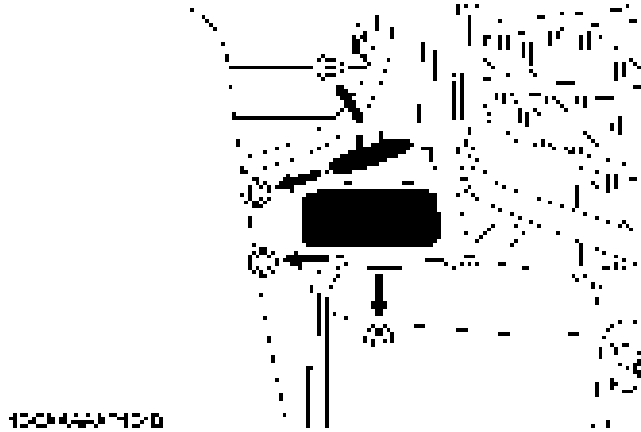

1504440712-D

- (A) "CHEST AREA"
- (B) "WINDSHIELD"
- (C) "CLOSED"



## CAUTION

To avoid personal injury;

- Replace the air-conditioner hoses every two years.
- Inspect daily.  
Have the machine repaired immediately if any of the following defects are discovered. (Such defects may cause burns or injury. They may also cause engine failure by serious damage.)
  - Scratches, cracks or swelling in air-conditioner hoses.
  - Water leaks at joints or connecting points.
  - Missing or damaged air-conditioner hose protective sleeve or grommet.
  - Loose mounting bolt, damaged bracket.
- Do not touch the air-conditioner hoses or the heater with your hand. You may get burned.
- If the window fails to defrost in extreme conditions or becomes cloudy when dehumidifying the cab, remove moisture with soft cloth.
- Never block all of the air outlets, system malfunction may occur.

## Control Panel



1504440712-D

- (1) Air-conditioner switch with indicator light
- (2) Temperature control lever
- (3) Blower switch

### ◆ Air-Conditioner Switch and Indicator Light

Push this switch to activate the air-conditioner. An indicator light will light up when the switch is set to "ON". Push switch again to turn air-conditioner off, in which case the indicator light will go off.

### ◆ Temperature Control Lever

Set this lever at the desired position to obtain the desired air temperature. Move the lever to the right to obtain cooler air. Move it to the left to obtain warmer air.

### ◆ Blower Switch

Air flow (fan speed) has three levels. At the "3" position, the largest air flow is obtained.

### NOTE :

- Air-conditioner is operable only during engine operation.

## ■ Operation

### ◆ Heating

1. Adjust the blower (1/2/3) switch and the temperature control lever to achieve the desired temperature level.

#### NOTE :

- In summer when the heater is not used, keep the temperature control lever at the "COOL" (rightmost) position. Otherwise, hot air will raise the temperature in the cab.

### ◆ Dehumidifying-heating

1. Press and turn on the air-conditioner switch.
2. Turn on the blower (1/2/3) switch.
3. Adjust the temperature control lever to the "COOL" or an intermediate position to achieve the desired temperature level.

#### NOTE :

- Be sure to close the door while the air-conditioner is ON.

### ◆ Cooling

1. Press and turn on the air-conditioner switch.
2. Turn on the blower (1/2/3) switch.
3. Adjust the temperature control lever to the "COOL" or an intermediate position to achieve the desired temperature level.

#### NOTE :

- Be sure to close the door while the air-conditioner is ON.

### ◆ Defrosting or demisting

To defrost or demist the windshield, take the following steps.

1. Open the front air outlet and direct it to the windshield.
2. Set the blower switch and the temperature control lever to the "3" and "WARM" (leftmost) positions, respectively.

# OPERATION OF THE ENGINE



## CAUTION

To avoid personal injury:

- To avoid the danger of exhaust fume poisoning, do not operate the machine in a closed building without proper ventilation.
- Always start the engine from the operator's seat. Do not start the engine while standing next to the machine. Before starting the engine, sound the horn to get the attention of persons standing nearby.

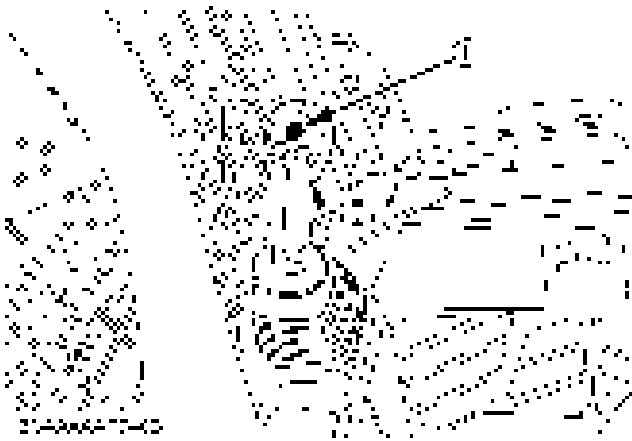

(1) Horn switch

## IMPORTANT :

- Do not use starting fluid or ether.
- In order not to overload the battery and starter, avoid start-ups of more than 10 sec.
- When engine does not start in 10 sec., please wait 20 sec. or more, before attempting to restart.

## STARTING THE ENGINE



## CAUTION

To avoid personal injury:

- The operator should not depend solely on the warning lamps, but should always conduct the routine checks section (see "MAINTENANCE" section).

Start the engine in the following manner:

1. Before starting the engine, make sure that the armrests are in the "Raised" position and the control levers are in their neutral position and the seat belt is fastened correctly.



- (1) Left control (traveling) lever
- (2) Right (front operating) lever
- (3) Armrest
- (4) Accelerator lever

2. Set the accelerator lever 1/2 way forward and keep the accelerator pedal free.

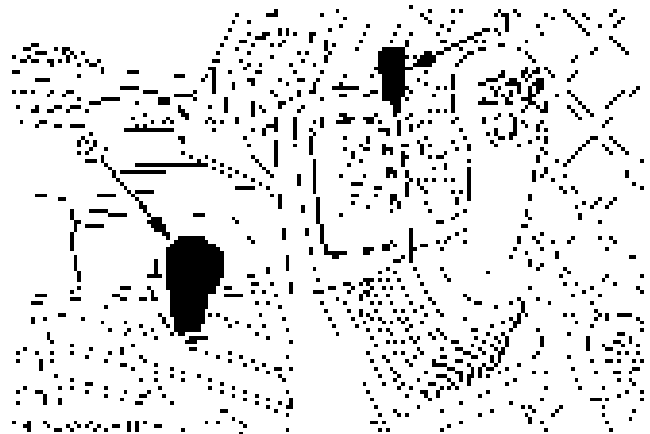

- (1) Accelerator lever
- (2) Accelerator pedal

3. Insert the key into the starter switch and turn it to the "RUN" position. The glow lamp will light up while the engine is preheated and will go out automatically after preheating is finished.



(1) Starter switch

(A) "STOP"  
(B) "RUN"  
(C) "START"

4. Make sure the "⚡" and "🔋" marks appear on the instrument panel.  
If not, the system is malfunctioned. Contact your local dealer.

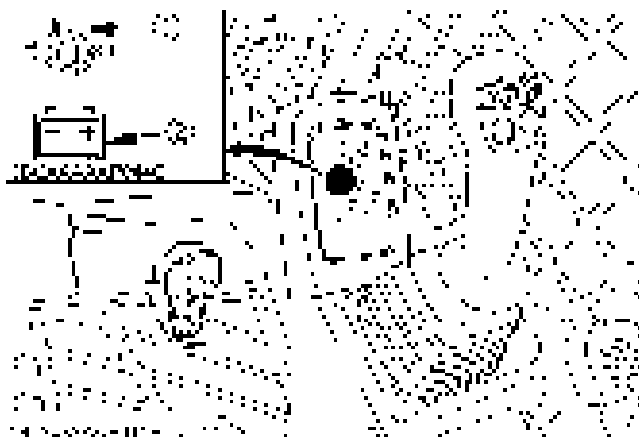

(1) Engine oil pressure warning lamp  
(2) Battery charge lamp

5. Turn the key to the "START" position and release after the engine has started.
6. Check if all warning lamps (except hydraulic lock lamp and parking brake lamp) have gone out. Should a warning lamp still be lit up, stop the engine then remove the key and check for the cause.

**IMPORTANT :**

- The starter motor consumes large current. Avoid running it longer than 10 seconds continuously. If the engine fails to start within 10 seconds, once set the key to the "STOP" position, wait for 20 seconds or longer, and repeat the above step 3 through 6.
- If the battery is dead and must be connected to another battery with jumper cable, be sure to use a 12V battery. Never use any 24V batteries.

**■ Checkpoints after Starting the Engine**

After starting the engine, but before starting operation, check the following points:

1. The engine idle allows the engine lubricant to warm up and penetrate every part of the engine.

**NOTE :**

- This idling is usually called "Warm-up".
2. Once the engine has warmed up, check:
    - the "Engine oil pressure warning lamp" has gone out.
    - the "Battery charge lamp" goes out when engine speed is increased.
    - the color of the exhaust is normal and no abnormal noises or vibrations are heard or felt.
    - no fluid is leaking from pipes or hoses.

**◆ Should any following conditions occur, stop the engine immediately.**

- The engine rpm's increases or decreases suddenly.
- Sudden abnormal noises are heard.
- Exhaust is black.
- Warning lamp for engine oil lights up during operation.

**IMPORTANT :**

- In these cases, the machine must be checked and serviced by your local the KUBOTA dealer.

## STARTING THE ENGINE UNDER COLD CONDITIONS



### CAUTION

To avoid personal injury:

- Make sure that the armrests are in the "Raised" position during warm up.

Start the engine in the following manner;

1. Turn the starter switch to the "RUN" position (glow position) and hold until the indicator lamp has gone out.
2. Move the starter switch to the "START" position; to crank and start engine.
3. Release the starter switch after the engine has started; it will automatically return to the "RUN" position.

### IMPORTANT :

- Let the engine warm up after start-up for approx. 10 minutes under no load conditions. If the hydraulic fluid temperature is too low, the operations or the function of the pressure sensors will be affected.  
Do not operate the machine under full load before the engine has warmed up enough.

## STOPPING THE ENGINE



### WARNING

To avoid personal injury or death:

- Do not keep the bucket or attachments in the lifted position, as a person could accidentally touch the levers and cause serious accidents.
- Place the machine on the flat ground.

1. After slowing the engine to idle, turn the key to "STOP" position.
2. Remove the key.

## STARTING WITH AN AUXILIARY BATTERY



### CAUTION

To avoid personal injury:

- Battery gases can explode.  
Do not smoke and keep sparks and flames away.
- Do not start the engine with an auxiliary battery if machine battery is frozen.
- Do not connect the black jumper cable to the negative (-) terminal of the machine battery.

### ■ Observe Following Guidelines when Starting with an Auxiliary Battery

1. Bring the helping machine with the same battery voltage as near as possible to the machine.  
THE MACHINES MUST NOT COME IN CONTACT WITH EACH OTHER.
2. Bring the levers and pedal of both machines in the neutral position.
3. Wear eye protection and rubber gloves.
4. Ensure the vent caps are securely in place (if equipped).
5. Connect the terminal of the red jumper cable with the plus (+) terminal of the low battery and connect the other end of the cable to the plus (+) terminal of the auxiliary battery.
6. Connect the black negative cable to the minus (-) terminal of the auxiliary battery.
7. Connect the other end of the black cable (coming from the auxiliary battery) to the conductive part of the machine frame as far away as possible from the low battery.
8. Start the engine of the helping machine and let it run for a while. Start the machine with the low battery.
9. Disconnect the jumper cables in the reverse sequence.

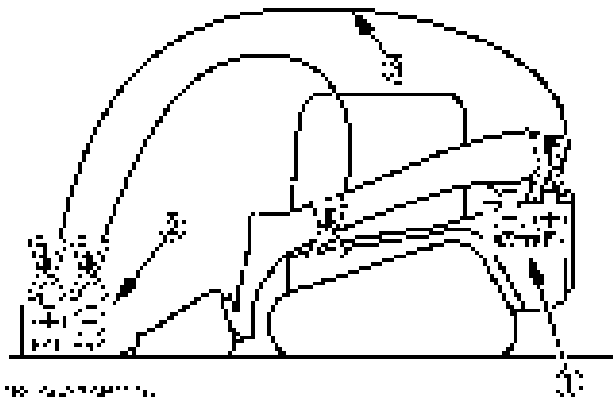

- (1) Low battery  
(2) Auxiliary battery  
(3) Jumper cables

### IMPORTANT :

- This machine has a negative (-) ground 12 Volt starting system.
- Only use the same voltage when using an auxiliary battery.
- Using a higher voltage will cause serious damage to the electrical system. When using an auxiliary battery, only the compatible (same) voltage is permissible.

# OPERATION OF THE MACHINE

## RUNNING-IN OF THE MACHINE

The operation and care of the new machine influences its life span. Your new machine has been carefully checked and tested before leaving the factory. In spite of this, all movable components must run-in during the first 50 work hours. Do not work with full rpm's and full loads during this period. It is most important to run-in your machine properly in order to achieve its full performance and longevity. During the running-in, the following points should be adhered to in all cases.

### ■ Do not Work with Full Engine Rpm's or Full Loads during the First 50 Working Hours

- Let the engine warm up sufficiently in the cold season.
- Do not let the engine rev-up more than necessary.

### ■ Oil Change in the Run-in Stage

The lubrication oil plays a specific and important role during the run-in phase of the machine. The numerous movable parts are not yet run-in, so many fine metal particles can be generated and may cause damage and shorten the life of many components. Pay attention to the oil-change intervals and complete them sooner than later. See "REGULAR CHECKS AND MAINTENANCE WORK" section for more details on the oil-change intervals.

## STARTING



### WARNING

To avoid personal injury or death:

- Mount the machine and dismount the machine only at locations that have steps and/or handholds.  
Before you mount the machine, clean the steps and the handholds.
- Start the only from the operator's seat.  
Never short across the starter terminals or across the batteries.  
Shorting could damage the electrical system by bypassing the engine neutral start system.
- Inspect the condition of the seat belt and the mounting hardware.  
Replace any parts that are worn or damaged.  
Do not use a seat belt extension on a retractable seat belt.
- Adjust the seat so that full pedal travel can be achieved with the operator's body against back of the seat.

- Make sure the machine is equipped with a lighting system that is adequate for the job conditions.  
Make sure all machine lights are working properly.
- Before you start the engine and before you move the machine, make sure that no one is underneath, or on, or close to the machine.

### ■ Adjusting the Operator's Seat



### WARNING

To avoid personal injury or death:

- Replace the operator's seat with the new one if damaged and made holes. Water or dust could penetrate the hole and it causes the erroneous OPC switch operation.



### CAUTION

To avoid personal injury:

- Make sure that the seat is completely secured after each adjustment.

[Suspension seat]

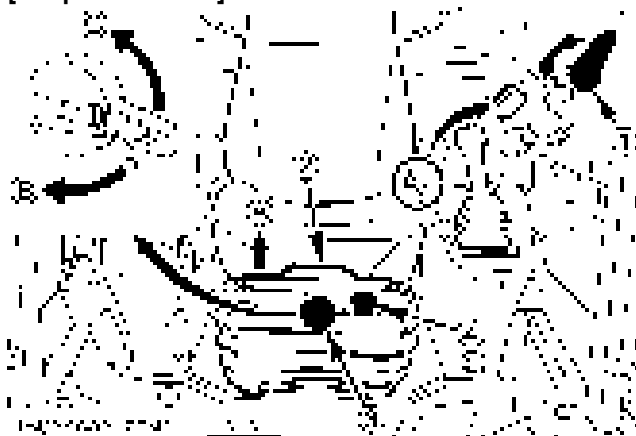

- |                                    |                         |
|------------------------------------|-------------------------|
| (1) Backrest tilt adjust lever     | (A) "UNLOCK"            |
| (2) Travel adjust lever            | (B) "TO RAISE THE SEAT" |
| (3) Weight and height adjust lever | (C) "TO LOWER THE SEAT" |
| (4) Ride indicator                 |                         |

**[Air-suspension seat]**

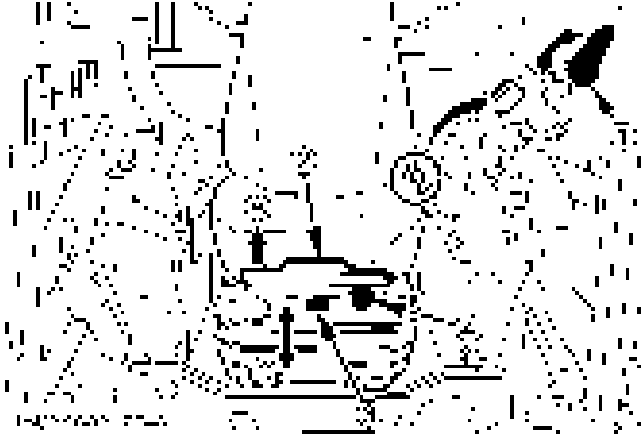

- (1) Backrest tilt adjust lever (A) "UNLOCK"
- (2) Travel adjust lever (B) "TO RAISE THE SEAT"
- (3) Weight and height adjust lever (C) "TO LOWER THE SEAT"
- (4) Ride indicator

**◆ Travel adjustment**

Pull the travel adjust lever in the direction of [A] and slide the seat backward or forward, as required. The seat will lock in position when the lever is released.

**◆ Weight and height adjustment**

Turn the weight and height adjust lever to achieve the optimum suspension setting. Make sure the ride indicator shows green. If red, readjust the suspension setting. Within the green band of the ride indicator, there is 60 mm (2.4 in.) of height adjustment for any operator.

**◆ Tilt adjustment**

Pull the backrest tilt adjust lever in the direction of [A] and move the backrest to the desired angle.

**■ Seat Belt**



**WARNING**

To avoid personal injury or death:

- Always use the seat belt with a ROPS/FOPS protection structure. Adjust the seat to the optimal position and buckle up.
- Always fasten the seat belt securely before starting the engine.

**◆ Fastening the seat belt**

1. Pull the seat belt from the retractable (right) side of the seat.
2. Insert the fixture into the socket at the left side of the seat until it clicks deep into position.

**◆ Releasing the seat belt**

1. Press the red button of the socket to release the seat belt.
2. The seat belt reels itself and gets retracted to the right side.

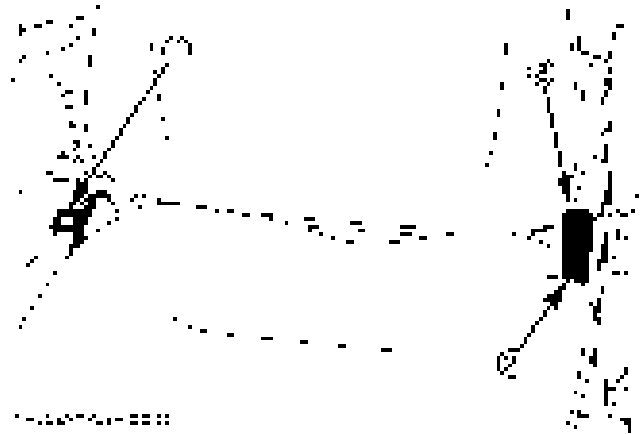

- (1) Seat belt
- (2) Socket
- (3) Button

**■ Armrest**

Move the armrests to the "RAISED" position to lock out the hydraulic and electric systems.



(1) Armrest

(A) "RAISE"

**NOTE :**

- When the armrests are moved to the "RAISED" position, the parking brake will engage and the hydraulic and operation system will be locked. Move the armrests to the "LOWERED" position and push the hydraulic unlock switch in order to activate the hydraulic controls.
- When you start the engine, the hydraulic lock must be disengaged so that the hydraulic controls are activated. If the armrests are raised and then lowered during the operation, you must disengage the hydraulic lock so that the hydraulic controls are activated.

## DRIVING



### WARNING

To avoid personal injury or death:

- Before starting the engine, make sure that no one is near the machine.

### ■ Forward and Backward Travel

#### ◆ To move forward:

Push the left control (traveling) lever forward.

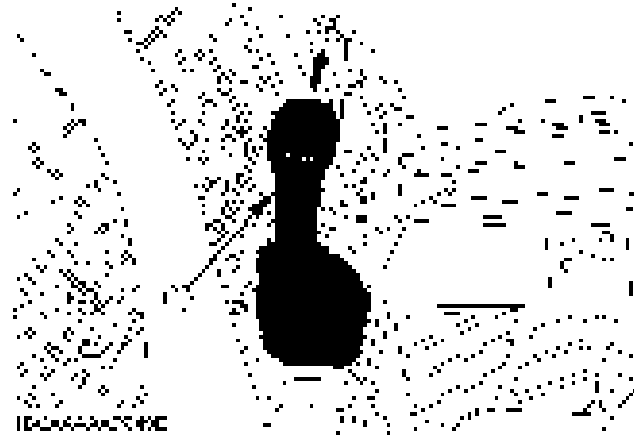

(1) Left control (traveling) lever (A) "FORWARD"

#### ◆ To move backward:

Pull the left control (traveling) lever backward:

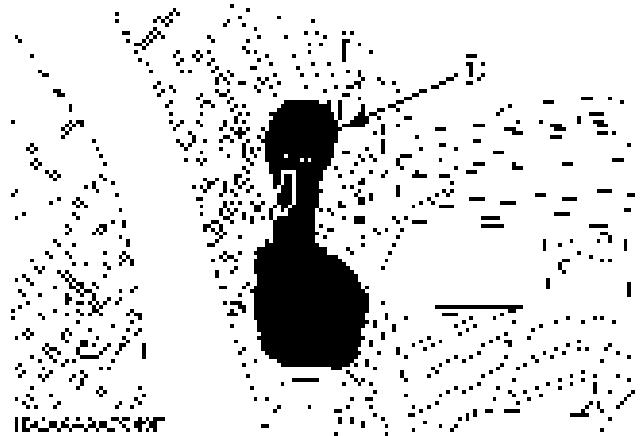

(1) Left control (traveling) lever (A) "BACKWARD"

#### NOTE :

- When the machine begins to travel "BACKWARD", the reserve alarm starts sounding.

#### IMPORTANT :

- If the hydraulic oil temperature is too low, the reserve alarm may start sounding when switching from the backward to the forward travel. This is not a problem. Just make a warm-up run, and then the hydraulic oil temperature rises, this will stop the alarm. If the alarm still keeps sounding, contact your local dealer.

# TURNING



## CAUTION

To avoid personal injury:

- Before changing direction, beware of people in the work area.
- Make sure the bucket or attachment is lowered on the ground.

### ■ Pivot Turn

#### ◆ To turn forward to the left:

Tilt the left control lever (traveling) forward to the left.

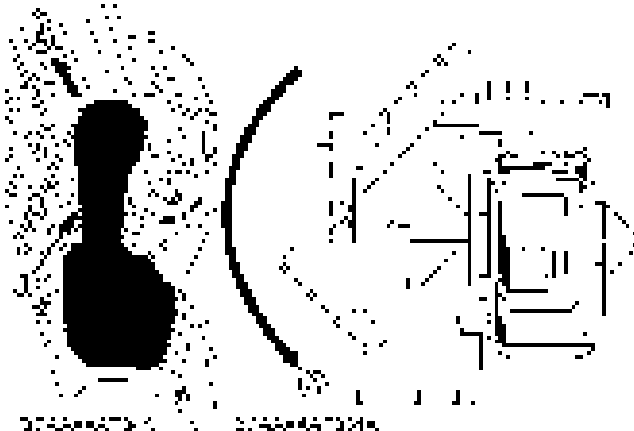

(1) Left control (traveling) lever (A) "TURN"

#### ◆ To turn backward to the left:

Turn the left control (traveling) lever backward to the left.

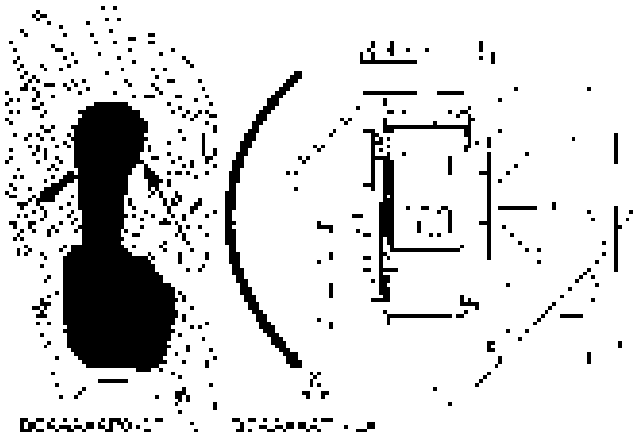

(1) Left control (traveling) lever (A) "TURN"

#### ◆ To turn forward to the right:

Tilt the left control lever (traveling) forward to the right.

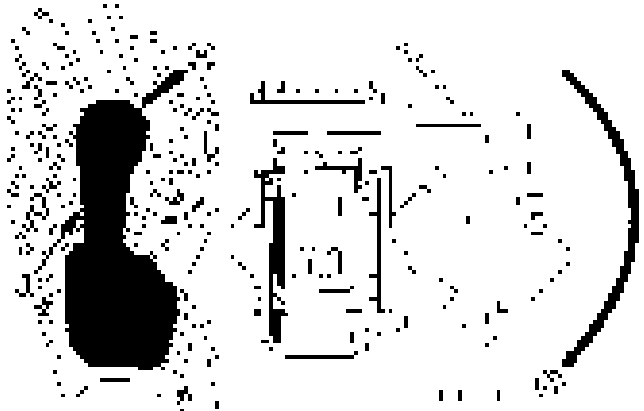

(1) Left control (traveling) lever (A) "TURN"

#### ◆ To turn backward to the right:

Turn the left control (traveling) lever backward to the right.

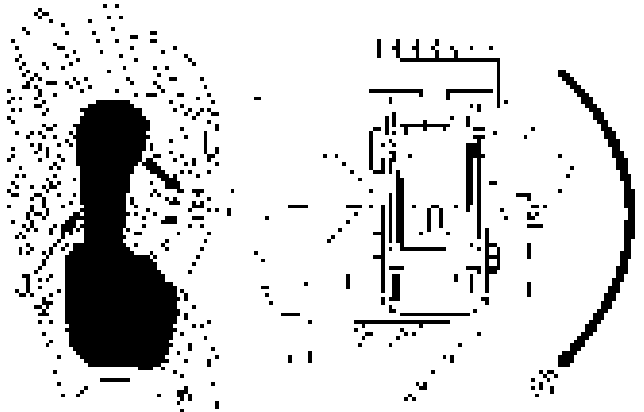

(1) Left control (traveling) lever (A) "TURN"

■ Spin Turn

◆ To spin left:

Tilt the left control (traveling) lever to the left.

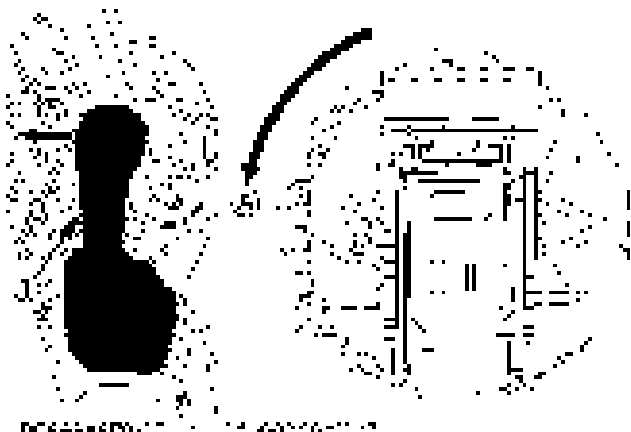

(1) Left control (traveling) lever (A) "SPIN"

◆ To spin right:

Tilt the left control (traveling) lever to the right.

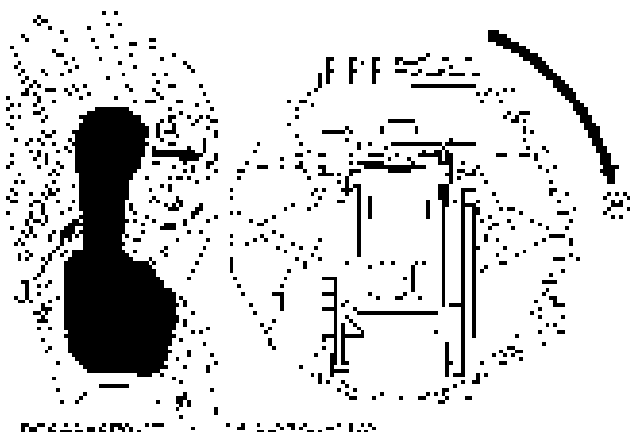

(1) Left control (traveling) lever (A) "SPIN"

OPERATION OF THE LIFT ARMS

◆ To lower the lift arms:

Push the right control (front operating) lever forward:



(1) Right control (front operating) lever (A) "LOWER"

◆ **To raise the lift arms**

Pull the right control (front operating) lever backward.

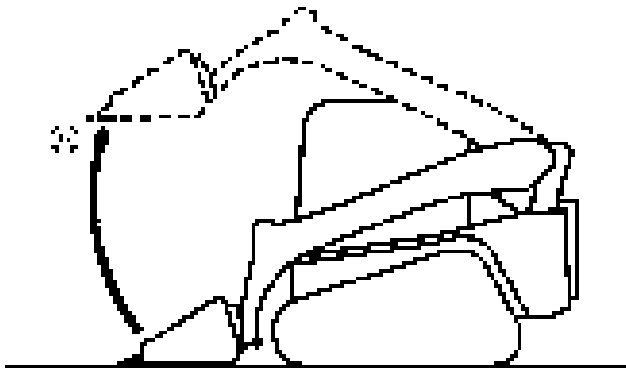
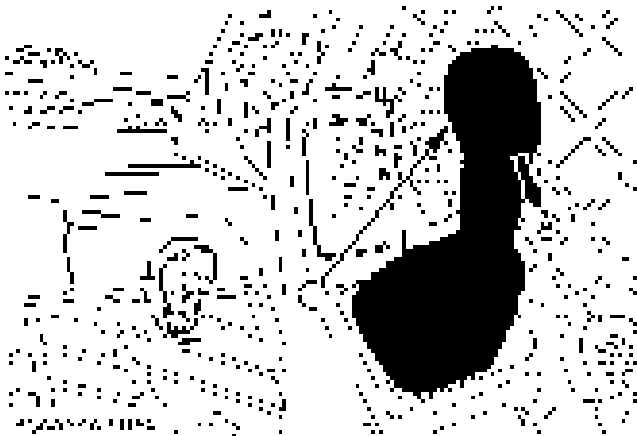

(1) Right control (front operating) lever (A) "RAISE"

**NOTE :**

- To stop the lift arm operation, return the right control (front operating) lever to the neutral position.



**WARNING**

To avoid personal injury or death:

- Do not exceed the rated operating capacity of the unit. If loads exceed this operating capacity, the unit can experience a hydraulic imbalance when half or medium "lift arms raise" and "bucket roll back" or "auxiliary hydraulic control" commands are input together, which can result in the lift arms lowering slowly. If you begin to experience this condition, either place the lift arms control in "neutral" or input full "raise" control, and lift arms lowering will cease.

■ **Lift Arm Stopper**



**WARNING**

To avoid personal injury or death:

- Never work on a machine with the lift arms up unless the lift arms are secured by an approved lift arm stopper.

The lift arm stopper is used to prevent the lift arms from falling when servicing the machine.

◆ **Installing**

1. Park the machine on level and firm ground and lower the lift arms fully to the ground. Remove the front attachment.
2. Stop the engine.
3. The second person should remove the lift arm stopper from the storage position.

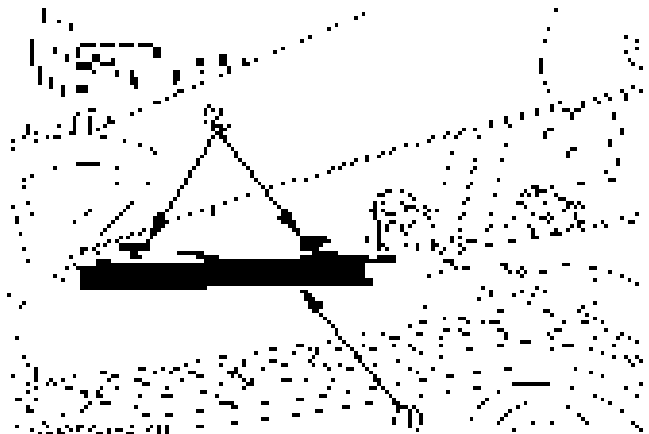

(1) Lift arm stopper  
(2) Knob bolt

4. Start the engine and set the parking brake switch to the parking position.
5. Slowly raise the lift arms to the maximum height and stop the engine. Operator must stay in the operator seat with the seat belt fastened.
6. The second person must install the lift arm stopper. Place the top (dented) of lift arm stopper upward and cover the rod with the stopper from front. Using one of the knob bolts, secure the stopper in position.

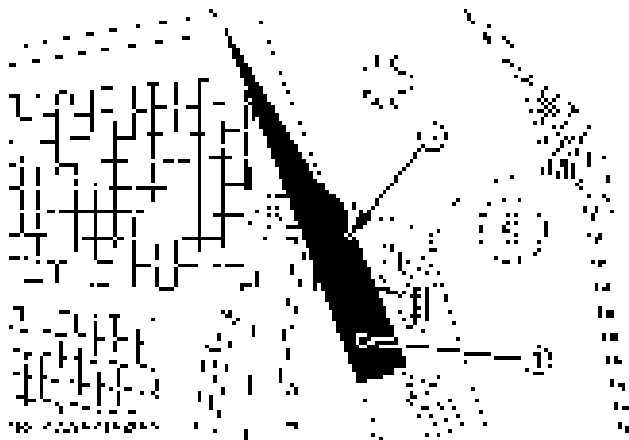

(1) Lift arm stopper  
(2) Knob bolt

7. Start the engine and set the parking brake switch to the parking position.
8. Slowly lower the lift arms against the lift arm stopper.

**IMPORTANT :**

- Make sure that the dent on top the lift arm stopper fits the round part of the lift arm and that the flat bottom of lift arm stopper fits the flat top of arm cylinder tube. No gap is allowed in both locations.

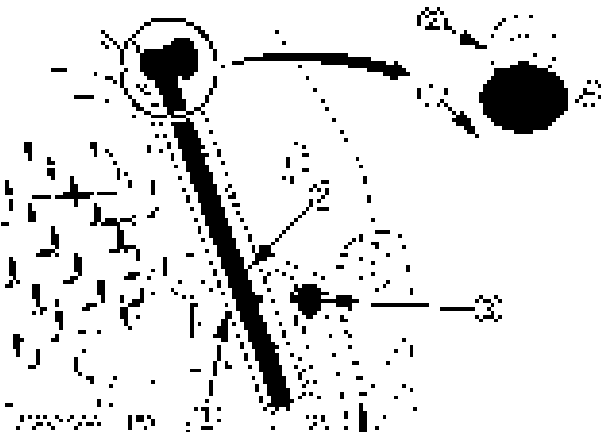

(1) Lift arm stopper  
(2) Arm cylinder tube  
(3) Knob bolt  
(A) "FIT"

**◆ Removing**

1. The operator should be in the operator's seat with the seat belt fastened.
2. Start the engine and set the parking brake switch to the parking position.
3. Slowly raise the lift arms to the maximum height and stop the engine.
4. The second person must remove the lift arm stopper.
5. Start the engine and lower the lift arms fully to the ground and stop the engine.
6. Return the lift arm stopper to the storage position and secure with two knob bolts.

**OPERATION OF THE BUCKET**

**◆ To roll back:**

Tilt the right control (front operating) lever to the left.



1200442970000

(1) Right control (front operating) lever (A) "ROLL BACK"



- Do not exceed the rated operating capacity of the unit. If loads exceed this operating capacity, the unit can experience a hydraulic imbalance when half or medium "lift arms raise" and "bucket roll back" or "auxiliary hydraulic control" commands are input together, which can result in the lift arms lowering slowly. If you begin to experience this condition, either place the lift arms control in "neutral" or input full "raise" control, and lift arms lowering will cease.

**■Auxiliary Hydraulic Control Operation**

1. Start the engine (refer to "OPERATION OF THE ENGINE" and "OPERATION OF THE MACHINE" section).
2. Press the hydraulic unlock switch.
3. Press the AUX port switch.

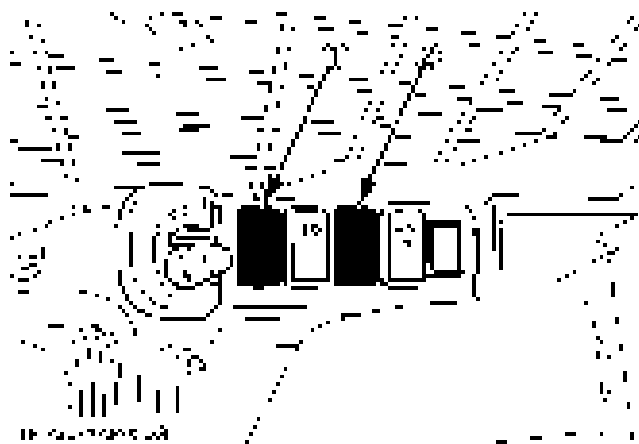

- (1) Hydraulic unlock switch.
- (2) AUX port switch.

4. Tilt the AUX port variable switch toward Side A or press the right AUX hold switch, and oil starts flowing out of Male port.



- (1) AUX port variable switch
  - (2) AUX hold switch
- (A) "Male port"  
(B) "Female port"

**NOTE :**

- The oil flow rate responds to the tilt of AUX port variable switch.
  - Press the AUX hold switch, and the oil continues to flow at its highest flow rate. To interrupt it, press this switch again.
5. If the tank must be drained, depending on an attachment in use, use the male case drain port.

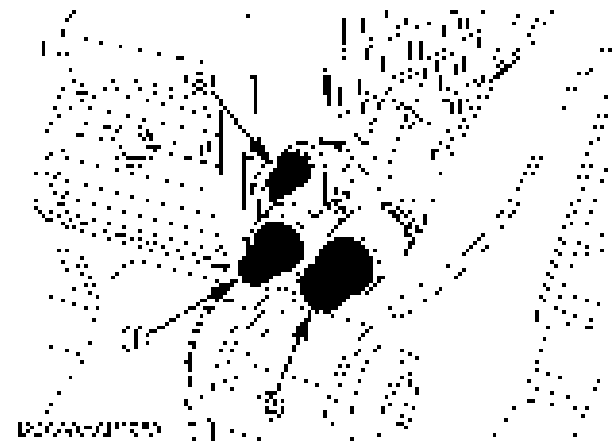

- (1) Male port
- (2) Female port
- (3) Male case drain port

## ATTACHMENT CONTROL DEVICE (OPTION)

This option is used to feed electrical power for an attachment (to drive a valve, for instance).

With the AUX port ready for use, power can be supplied.

K: +12V and B: GND of the 14-pin coupler attached on the arm (see below)

### NOTE :

- The K (+12V) of the 14-pin coupler turns on when the starter switch is in "RUN" position.

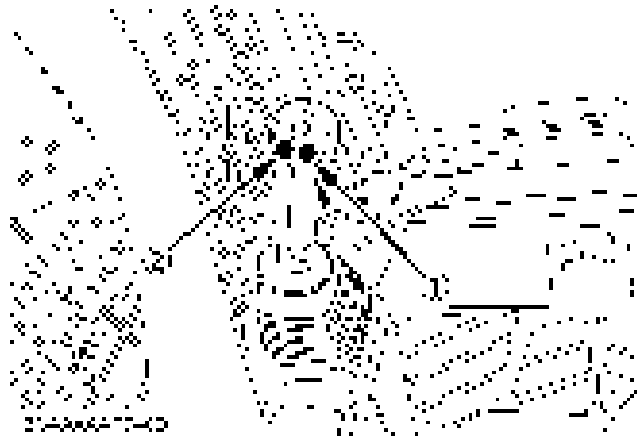

(1) AUX electrical control switch (Right)  
(2) AUX electrical control switch (Left)

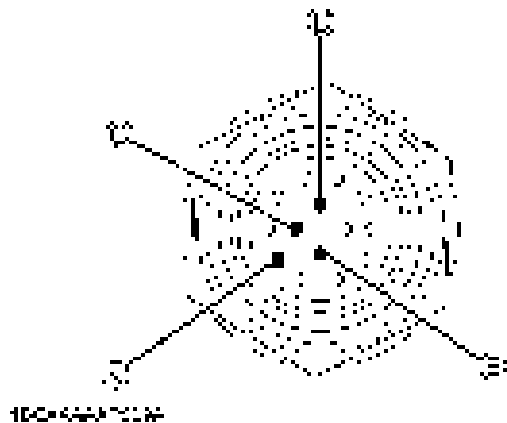

### ◆ Operation

Press the right electrical control switch of the left lever to have "D" at +12V and the left electrical control switch to have "C" at +12V. In this way, the valves connected with them can be activated.

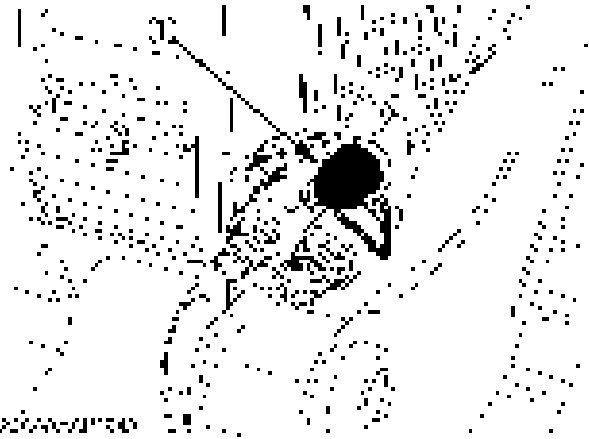

(1) 14-pin coupler

## MECHANICAL QUICK-HITCH

### ■ Attaching Attachments

This machine utilizes a quick-hitch for easy connection and disconnection of various attachments.

By replacing the front attachments, this machine can be used in agriculture, raising stock, landscaping, gardening and snow removal as well as general civil engineering and construction work.



### DANGER

To avoid personal injury or death:

- Use of attachments that do not comply with ISO24410 or the improper positioning of lever(s) or non-protrusion of pin(s) may result in detachment of the attachment or deformation, causing loss of performance, personal injury or death.



### WARNING

To avoid personal injury or death:

- After doing these procedures, make sure the attachment is securely attached to the quick-hitch, or the attachment may be detached.
- When handling the control lever, you should do it after setting the change lever to the neutral position and the parking brake switch to the parking position, lowering the lift arm, locking all control levers in neutral position.

**NOTE :**

- Attachments should be located on a level, firm surface when attaching and detaching them from the quick-hitch.
1. To mount an attachment, pull the levers of the quick-hitch lock pins to the "UNLOCKED" position. The quick-hitch levers must be all the way up to ensure that the lock pins are fully retracted.
  2. Position the machine squarely in front of the attachment and tilt the quick-hitch forward with the tilt cylinders.



(1) Quick-hitch

3. Ease the quick-hitch mounting plate into the saddle of the attachment.
4. Roll the quick-hitch back using the tilt cylinders and raise the lift arms slightly. The back of the attachment should rest against the front of the quick-hitch mounting plate and the weight of the attachment should be supported by the lift arms.



(1) Quick-hitch

5. When the attachment is properly seated in the saddle and against the front of the quick-hitch mounting plate, turn off the engine and set the parking brake. Push the quick-hitch levers to the fully "LOCKED" position. Verify both lock pins are completely engaged in the base of the attachment.



(1) Quick-hitch lever

(A) "LOCK"

6. With an attachment in place, lift the lift arms and empty out the bucket. Tilt the bucket downwards and verify the lock pins are fully engaged.



**DANGER**

To avoid personal injury or death:

- The following engagement points are critical.
  - 1) The lock pins of the quick-hitch have to protrude into and through the pin slots of the attachment on both sides.  
It is critical that the pins are in good condition and without visible signs of wear or damage and that the operator align the quick-hitch with the attachment to allow the pins to go through the pin slots.
  - 2) Both levers have to be pushed down until the levers contact the ear plates near the points where the pin bolt goes through the lever (A).
  - 3) Do not operate the machine or attachment unless all of the above conditions are met.

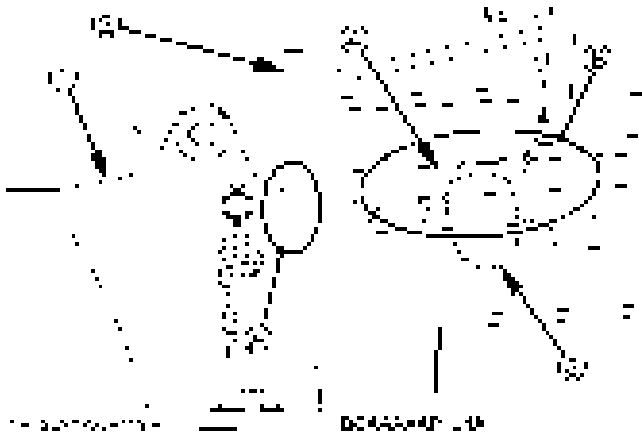

- (1) Lever
  - (2) Ear plate
  - (3) Lock pin
  - (4) Pin slot
- (A) "The lever contacts the ear plate at the points."  
 (B) "The pin protrudes through the slot."

7. Visually verify when pushing the quick-hitch levers into locked position that the lock pins protrude through the slot.
8. When attaching different attachments visually inspect for broken or damaged pins. If broken or damaged pins are found, replace before using. Use of broken pins may result in detachment or deformation, causing loss of performance, personal injury or death.
9. You are now ready to use the attachment.



**CAUTION**

- To avoid personal injury or machine damage:
- Never operate or transport attachments which are not attached completely.
  - Always replace damaged hardware immediately.

**Detaching Attachments**

1. Lower the attachment to ground level with the attachment slightly in the rolled back position. Stop the engine (the parking brake automatically engages.).
2. Disconnect the attachment's electrical harness and hydraulic lines from the lift arms if equipped.
3. Pull the quick-hitch lever up to the unlocked position to release the lock pins.
4. While sitting in the machine operator's seat, start the engine and slowly move the right control (front operating) lever to the "DUMP" position until the attachment is pushed away from the quick-hitch.
5. Lower the lift arms so that the quick-hitch mounting plate clears the attachment saddle.
6. Back away from the attachment slowly.
7. If an attachment is not going to be attached to the quick-hitch immediately, push the lever of the quick-hitch to the locked position to prevent damage to the lever assembly.

**HYDRAULIC QUICK-HITCH (OPTION)**

**Attaching Attachments**

**NOTE :**

- Attachments should be located on a level, firm surface when attaching and detaching them from the quick-hitch.

1. Push the hydraulic quick-hitch switch in "UNLOCKED" position and hold it to make sure the levers are up ("UNLOCKED" position).

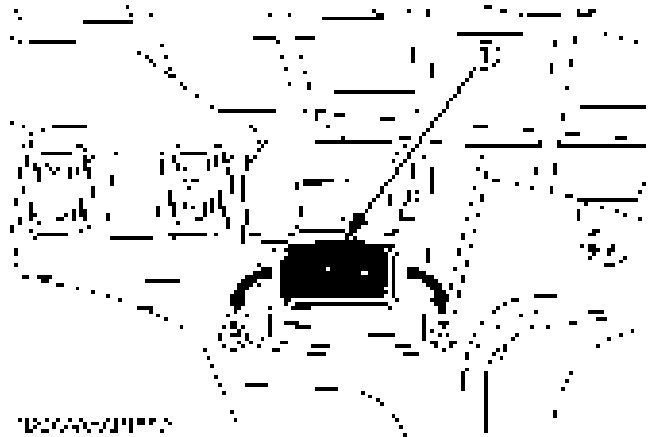

- (1) Hydraulic quick-hitch switch
- (A) "UNLOCK" position
- (B) "LOCK" position



- (1) Quick-hitch lever
- (A) "UNLOCK"

- Position the machine squarely in front of the attachment and tilt the quick-hitch forward with the tilt cylinders.



(1) Quick-hitch

- Ease the quick-hitch mounting plate into the saddle of the attachment.
- Roll the quick-hitch back using the tilt cylinders and raise the lift arms slightly. The back of the attachment should rest against the front of the quick-hitch mounting plate and the weight of the attachment should be supported by the lift arms.



(1) Quick-hitch

- When the attachment is properly seated in the saddle and against the front of the quick-hitch mounting plate, push and hold the hydraulic quick-hitch switch in locked position until the levers are fully in locked position. Verify both lock pins are completely engaged in the base of the attachment.



(1) Quick-hitch lever

(A) "LOCK"

- With an attachment in place, lift the lift arms and empty out the bucket. Tilt the bucket downwards and verify the lock pins are fully engaged.



## DANGER

To avoid personal injury or death:

- The following engagement points are critical.
  - The lock pins of the quick-hitch have to protrude into and through the pin slots of the attachment on both sides.  
It is critical that the pins are in good condition and without visible signs of wear or damage and that the operator align the quick-hitch with the attachment to allow the pins to go through the pin slots.
  - Both levers have to be pushed down until the levers contact the ear plates near the points where the pin bolt goes through the lever (A).
  - Do not operate the machine or attachment unless all of the above conditions are met.

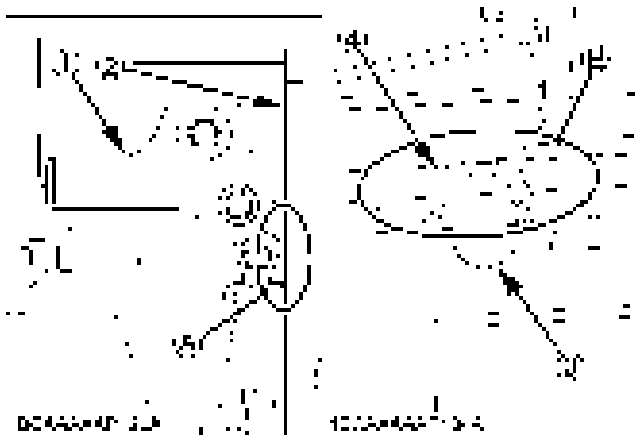

- (1) Lever
- (2) Ear plate
- (3) Lock pin
- (4) Pin slot

- (A) "The lever contacts the ear plate at the points."
- (B) "The pin protrudes through the slot."

7. Visually verify when pushing the quick-hitch levers into locked position that the lock pins protrude through the slot.
8. When attaching different attachments visually inspect for broken or damaged pins. If broken or damaged pins are found, replace before using. Use of broken pins may result in detachment or deformation, causing loss of performance, personal injury or death.
9. You are now ready to use the attachment.



## CAUTION

To avoid personal injury or machine damage:

- Never operate or transport attachments which are not attached completely.
- Always replace damaged hardware immediately.

## ■ Detaching Attachments

1. Lower the attachment to ground level with the attachment slightly in the rolled back position. Stop the engine. (The parking brake automatically engages.)
2. Disconnect the attachment's electrical harness and hydraulic lines from the lift arms if equipped.
3. Start the engine and push the hydraulic quick-hitch switch in "UNLOCKED" position. Hold it to make sure the quick-hitch levers are up.
4. While sitting in the operator's seat, and slowly move the right control (front operating) lever to the "DUMP" position until the attachment is pushed away from the quick-hitch.
5. Lower the lift arms so that the quick-hitch mounting plate clears the attachment saddle.
6. Back away from the attachment slowly.

## IMPORTANT INFORMATION ON MACHINE OPERATION

- Do not operate machine on loose rock or gravel (hard or soft).
  - Avoid moving machine when lift arms and bucket are in the raised position. If you must move the machine when they are raised, take care to travel at low speeds in order to maintain control of the machine at all times.
  - Always avoid working on an incline as the machine can become unstable and rollover, causing serious injury or death.
  - Whenever the machine is in motion, keep the bucket as close to the ground as possible. Never change directions when the bucket is in the raised position.
  - Always move the machine at speeds that are appropriate to the conditions. Take particular care if you are ever moving through areas where view may be obstructed or when transporting hazardous material.
  - Never operate the machine in the vicinity of explosive gases. Always keep exhaust from machine away from any combustible material.
  - Never turn or spin the machine at high speed.
  - Never approach an incline horizontally, which can cause the track to slide off and cause excessive wearing of tracks.
  - Never exceed the operating capacity of the machine.
  - Never use the machine to move material or perform work that exceeds the capacity of the bucket or attachments.
  - Never use the bucket as a hammer to drive poles or studs into the ground.
  - Never attempt to dig too deeply with the bucket, which can damage the bucket or lift arms.
  - Avoid hitting the bucket against rocks or similar solid material, which will damage the bucket or bucket cylinder.
  - Never fully extend cylinders to perform an operation. Working while cylinders are fully extended can cause damage from excessive force.
  - Never scoop or grade areas while the tilt cylinders are fully extended. Extremely heavy loads apply excessive traction force to the bucket cylinders and can cause damage. Avoid loads that are too heavy.
- ## ■ Caution While Traveling
- Running over large debris (rocks, stumps, blocks, etc.) may cause such debris to fly up and damage the machine. Avoid such debris whenever possible.
  - If obstacles cannot be avoided, travel slowly over them with the bucket in the lowered position. Approach the obstacles so it is at the center of the tracks.



- Braking is automatic with the HST system when the left control lever is in the neutral position. Raise armrests for parking brake.

#### ◆ What to do when engine stops suddenly

- If the engine stops suddenly when moving down an incline, put control levers into neutral, stop the machine and then restart in the normal manner.

#### ■ Parking on an Incline

- It is best to park the machine on firm, level ground using the parking brake but if you must park the machine on an incline, make sure you block it to prevent any movement.
- Make sure the machine is highly visible when parking near streets by using barriers, appropriate caution signs, lights, etc. to avoid any accident or collision with other vehicles.
- Always raise the armrests to the "RAISED" position and stop the engine before leaving the operator's seat.
- Never leave the machine running unattended or with the lift arms raised. Whenever lift arms are raised, they MUST always be restrained using the lift arm stopper.
- Whenever leaving the machine, perform the following procedure:
  - Put control levers into neutral.
  - Return the throttle lever to idle.
  - Lower the bucket to the ground.
  - Move armrest in the "RAISED" position.
  - Turn off the engine and remove the key.

#### ■ Prohibited Actions

Actions that MUST NOT be performed with the machine:

- Never move, transport material or operate the machine in the following places:  
Mud, broken stone, jagged or unstable base rock, iron beams, iron scrapes, iron sheets, etc. Navigating, turning and moving the machine over sharp material may damage or break the tracks.
- Traveling on riverbeds and other areas where loose gravel can get into the tracks, causing them to slip off or become damaged.
- Do not use near the oceanfront where salt water can corrode the various parts of the machine.
- Always prevent fuel, oil, salt or other chemical agents from getting into the tracks, which can cause corrosion to the metal track cores. If the track and its parts are exposed to such material, immediately remove by using water.
- Always avoid traveling on roads directly after they have been resurfaced or other hot surfaces such fire or metal surfaces under direct sunlight. Excessive heat can cause irregular wear and damage to tracks.
- Do not attempt to move material where the surface is unstable and could cause slippage in the tracks. Unnecessary and excessive slipping of tracks will damage and cause abnormal wearing of the tracks.



#### CAUTION

To avoid personal injury:

- Whenever operating the machine, do the following:

- 1) Always avoid sudden changes in direction, or spinning on concrete surfaces. Excessive friction on the tracks will cause them to wear out or become damaged.
- 2) Always avoid sudden impact to the tracks such as allowing the machine to drop down or hit objects.
- 3) Chemical such as salt, potassium chloride, ammonium sulfate, potassium sulfate, triple-super phosphate of lime, etc., can damage the track belts. If the tracks are exposed to any of these substances, immediately wash thoroughly with water.
- 4) Avoid scraping the rubber tracks along concrete, and other rough surfaces.
- 5) Take particular care when operating, transporting material or traveling in snowy conditions or on ice as tracks may slip.
- 6) Operate the machine between -20°C and +50°C (-4 to 122°F) for proper functioning of rubber track belts.
- 7) If machine must be stored for 3 months or longer, keep it indoors, out of direct sunlight and prevent exposure to the elements to prevent wear on the rubber tracks.

#### ■ Preventing Slippage of Rubber Tracks

Always do the following to prevent slippage of rubber tracks:

- Make sure tracks are kept at the proper tension. Never change directions when there is excessive slack in the track belts.
- When ascending an incline, never change direction at the base of the incline.
- Always avoid operating the machine with one track on a different surface than the other track, or with one track partially on an incline. Make sure both tracks are on stable, firm surfaces when in motion.

# LIFTING THE MACHINE



## DANGER

To avoid serious injury or death:

- The instructions for safe lifting are described here. Read these instructions carefully before lifting the machine. Make sure that the operating personnel read the operator's manual carefully before lifting.

### IMPORTANT :

- Select a firm level surface, lower the working equipment to the ground, stop the engine, set arm rest to locked position and apply parking brake switch so the unit cannot roll.
- Do not lift loads that exceed the maximum rated capacity of the hoist and attaching hardware.
- See specifications for attaching hardware and choose hardware suitable for the weight, size and configuration of the load.
- Assess the center of gravity of the load, position the hook directly over the load and lift the load so that it remains horizontal.
- Do not enter and do not allow others to enter the working area under the suspended load and do not move the load over people. The load must only be moved in an area where the equilibrium can be maintained.
- Always inspect the attaching hardware, including chains, hooks and master links before each use. Do not use any worn or damaged attaching hardware or if the safety latch is missing.
- Do not use attaching hardware, including chains, hooks and master links, in extreme temperature or other environmental conditions that exceed the manufacturer's specifications.
- Load disengagement can cause severe injury or death. The use of a hook with a safety latch or other master link device does not preclude inadvertent detachment of a slack sling load from the hook or master link. Visual verification of proper hook or shackle engagement is required in all instances.
- Comply with all Federal, State and Local regulations and safety standards before lifting the machine.
- Do not use the holes on the roof structure to lift the machine.
- Make sure the lifting chains, hooks and master links are strong enough to withstand the load being lifted.
- Be sure that the hooks used have safety latch.
- Before lifting, be sure attachments are properly attached.

### Preparations

- Lifting chains (with hook at each end)  
Approximate overall length: 3.43 m (135 in.), 2 pc.  
Approximate overall length: 8.84 m (348 in.), 1 pc.
- Pads (to protect the machine and lifting chain)
- Master links, 2pc.

Model name	SVL 75-2*	
Model Type	Open Cab	Closed Cab
CTL weight ** kg (lbs.)	4100 (9039)	4225 (9314)
Recommended Chain Working Load Limit > 2565 kg (5655 lbs) ***	3/8" Lifting Grade 80 Alloy	
Recommended Master Link Working Load Limit > 5125 kg (11300 lbs) ***	Size not specified	
Recommended Attachment Hardware Working Load Limit > 2565 kg (5655 lbs) ***	Size not specified	

\* SVL 75-2 Weight shown with optional 15.5 inch wide track

\*\* SVL weight with standard (non-hydraulic) bucket

\*\*\* Recommended chain, master link and attachment hardware shall meet OSHA regulations and applicable ANSI, NACM, and Federal standards



**WARNING**

To avoid personal injury or death:

- Do not use damaged chains and lifting hardware.

**Procedure for connecting chains**

(1) **Chain locations and hook positions**

- Front of the machine:  
Pass the chain between the front idler and the front track roller, under the machine on each side, as shown in Fig. 1 and Fig. 2.

[Fig. 1][Chain location at front of the machine]



- (1) Front track roller
- (2) Front idler
- (3) Front lifting chain

[Fig. 2][Front view]

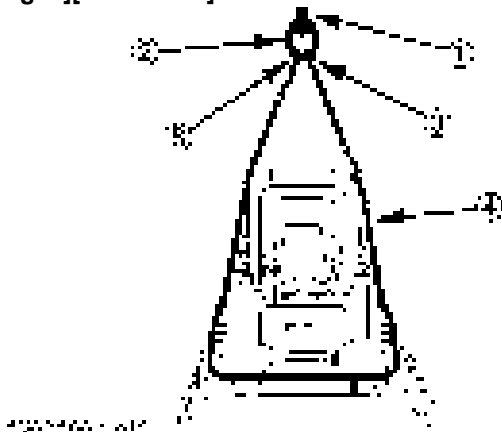

- (1) Hoist hook
- (2) Front master link
- (3) Hook
- (4) Front lifting chain

- Hook positions at rear of the machine  
Lifting fixture mount at rear corners of the machine.

[Fig. 3][Hook positions at rear of the machine]



- (1) Hook
- (2) Lifting fixture mount (Rear tie down point)

(2) **Connection of the hook**

- At the front of the machine, use the 8.84 m (348 in.) chain length. Pass the lifting chain and hook between front track roller and front idler under machine and again between front track roller and front idler at other side.
- Connect both hooks to front master link and connect the master link to the hoist hook as shown in Fig. 4.
- At the rear of the machine, use the 3.43 m (135 in.) chain length. Attach one end at the rear lifting fixture mount and attach the other hook to master link, then connect the master link to the hoist hook as shown in Fig. 3 and Fig. 4.

[Fig. 4][Hoist hook and master links]

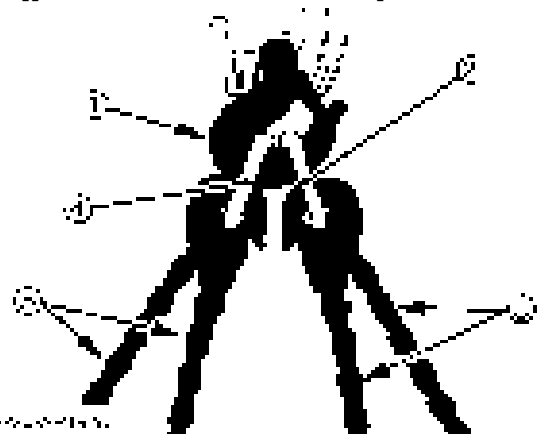

- (1) Hoist hook
- (2) Front master link
- (3) Front lifting chain
- (4) Rear master link
- (5) Rear lifting chain

**IMPORTANT :**

- Be sure to pass the rear lifting chains to the sides of the machine body as shown in Fig. 3 and Fig. 5.

(3) **Applying the pads**

Apply the pads at locations shown in Fig. 5 and Fig. 6, where the chains come in contact with the machine to reduce machine and chain damage.

◆ **Locations to apply the pads**

- Cab top
- Lift arm
- Track
- Track frames
- Rear lifting chains contact locations (frame and lift arm)

**IMPORTANT :**

- Never put yourself around the machine when lifted.
- Never lift the machine with person in operator station or on the attachment.

- (4) Before lifting, locate the hoist hook at the point which is shown in Fig. 5 and Fig. 6.

**Procedure for lifting**

- (1) Lift slowly and vertically.
- (2) Move the machine slowly into place.

[Fig. 5][Lifting chain with pads]

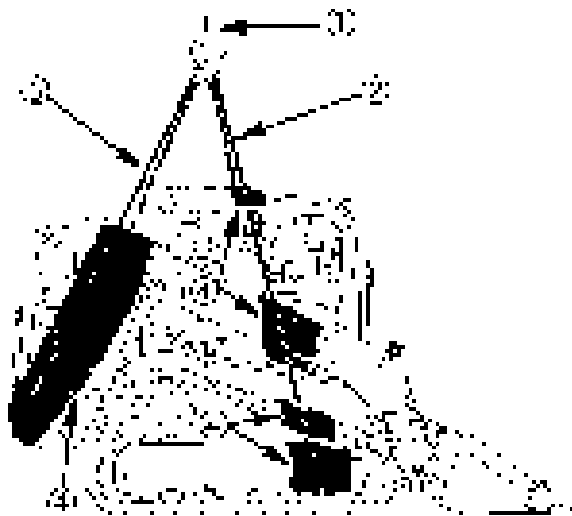

- (1) Hoist hook
- (2) Front lifting chain (8.84 m (348 in.))
- (3) Rear lifting chain (3.43 m (135 in.))
- (4) Pads

[Fig. 6][Front lifting chain location]

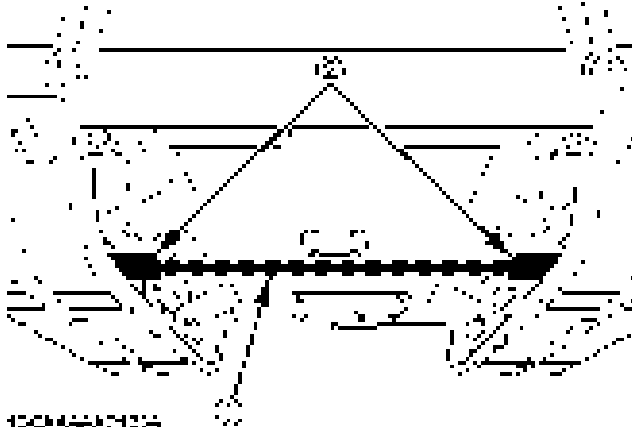

- (1) Front lifting chain (8.84 m (348 in.))
- (2) Pads

# TRANSPORTING THE MACHINE



## DANGER

To avoid personal injury or death:

- Make sure the ramps load capacity is greater than the machine and attachment weight.
- Make sure the ramps are clean, not damaged and properly secured to the transport bed.
- Position the machine so that the heaviest end of the machine is going up the ramps first.
- No directional changes should be made when the machine is on the ramp. Should a change of direction be necessary, drive off the ramp completely and make the turn.
- When the machine reaches the point between the ramps and the bed, move very slowly until the machine reaches the horizontal position on the bed.

## LOADING THE MACHINE ON A TRANSPORT VEHICLE



## WARNING

To avoid personal injury or death:

- When preparing to load or unload the machine, follow the below steps;
  - 1) Use a truck and trailer with sufficient size and weight capacity to transport the machine with attachment. Use of truck or trailer with an underrated capacity can cause unpredictable handling and loss of control. Always comply with government transportation laws and regulations.
  - 2) Apply the parking brakes on the truck, and block the drive wheels both sides as shown below.

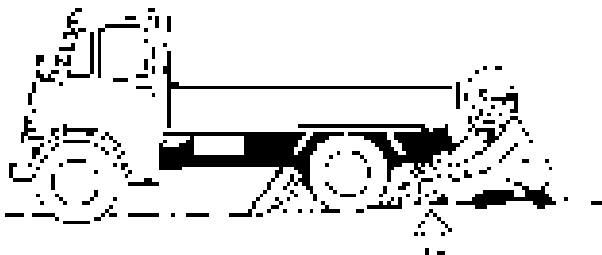

- 3) Use mounting brackets to secure ramps properly to the truck or trailer.
- 4) Determine and use the correct length of ramps to avoid a steep angle of approach as shown below.
- 5) If necessary, support the rear end of the bed to prevent the truck / trailer front from rising.

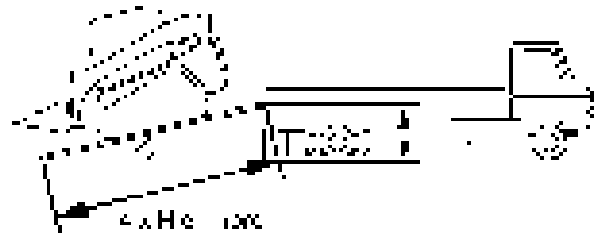

- 6) Align the machine with the ramps before traveling on ramps and if the ramps are wet, use caution during loading.
- 7) Load the machine with empty bucket or no attachment installed, and with the rear of machine going up the ramp first.
- 8) If the bucket or attachment is installed, avoid the bucket or attachment contact with ramps during travel.

- 9) Once the machine is loaded, lower the bucket or attachment completely.
- 10) Stop the engine, remove the key and set the parking brake.
- 11) Block the tracks and tie down the machine using 2 tie-downs at the front and 2 tie-downs at the rear.



(A) Front tie-down locations (both sides)

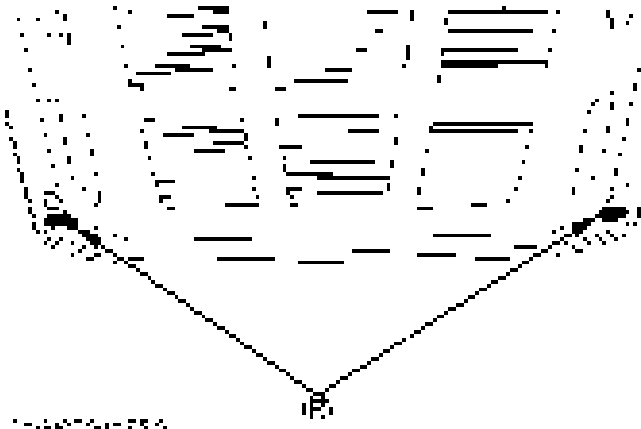

(B) Rear tie-down locations

- 12) Depending on the attachment installed, the loader arms may not come in contact with rest stop; therefore it may be necessary to use the alternate front center tie-down for securement of the machine. Use two separate straps or chains as shown below and secure the attachment with a separate strap or chain. Consult your government transportation laws and regulations.

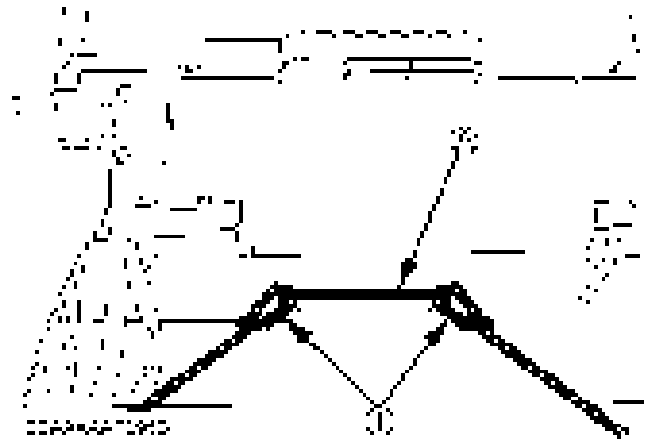

(1) Chain or strap

(A) Alternate front tie-down

- 13) When installing chains or strap from machine tie-down location to truck or trailer tie-down points, maintain proper angles to provide lateral and downward securement.
- 14) When using alternate or standard tiedown points, be sure to also tiedown the attachment in addition to the machine.

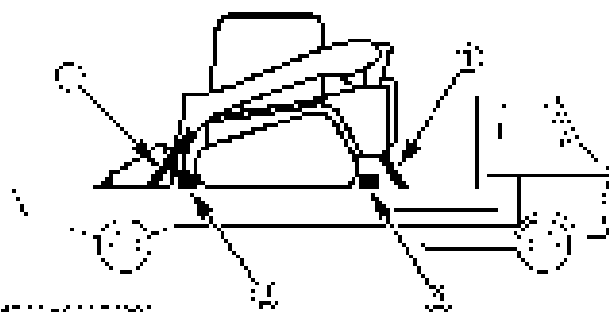

(1) Chain or strap  
(2) Blocks

## TOWING AN OPERABLE MACHINE



### WARNING

To avoid personal injury or death:

- Tow only from both rear tie-downs as shown below.
- Towing is only allowed for a short distance at walking speed.
- Use a tow chain or rope and hardware that is rated at least 1.5 times the machine weight. Refer to "TECHNICAL DATA" section in operator's manual to find machine weight.

1. Attach towing hardware using both rear tow points and to towing machine as shown below.
2. The operator must be seated in the towed machine with seat belt connected during the recovery process and assist when towed using machine movement in the direction of towing.
3. Tow slowly at a walking pace with recovery machine and towed machine, avoid abrupt loads while towing.

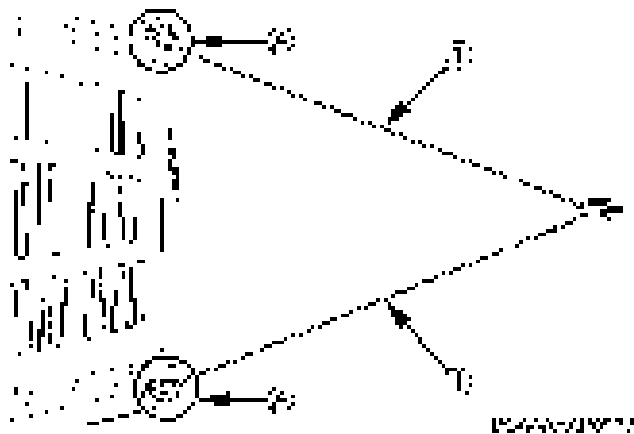

(1) Chain or strap (A) Rear tow and tie-down points



### CAUTION

To avoid personal injury :

- Do not tow this machine using the front tie-down attachment points located on each side of the lift arms or tie-down point at center of machine (A).



(A) Tie-down point

## TOWING AN INOPERABLE MACHINE



### WARNING

To avoid personal injury or death:

- Do not tow machine without disengaging hydraulic drive system, otherwise damage to the hydraulic drive or track system will occur.
- Follow proper procedures to disengage hydraulic drive system before towing machine. After disengaging hydraulic drive system, tow the machine following the below steps. Contact your KUBOTA dealer for more information.
- Tow only from both rear tie-downs as shown in the figure to the left.
- Towing is only allowed for a short distance at walking speed.
- Use a tow chain or rope and hardware that is rated at least 1.5 times the machine weight. Refer to "TECHNICAL DATA" section in operator's manual to find machine weight.

1. Attach towing hardware using both rear tow points and to towing machine as shown in the figure to the left.
2. Tow slowly at a walking pace with recovery machine and towed machine, avoid abrupt loads while towing.

# MAINTENANCE



## CAUTION

To avoid personal injury:

- Before doing maintenance work on the machine, place the machine on a firm, flat and level surface, lower the lift arms slowly to the ground, stop the engine.

Whether the machine is properly lubricated and maintained directly determines the trouble frequency and service life of the machine. Periodically check and maintain your machine, and you will find in the long run that the jobs can be finished earlier and more economically.

Shown in the Service Interval Chart below are the hours indicated on the hourmeter, practically, it will be convenient to schedule the time of inspection and maintenance according to the calendar (day, week, month) on the basis of the chart. If the machine is used in harder-than-usual working conditions, it must be checked and maintained at shorter intervals.

## MAINTENANCE INTERVALS

No.	Check points	Measures	Hour meter indicator						Interval	Ref. page				
			50	250	500	1000	1500	2000					3000	
1	Coolant	check	Daily check						(every 10 hrs)	58				
		change							every 2 years	76				
2	Fuel	check	Daily check						(every 10 hrs)	59				
3	Engine oil	check	Daily check						(every 10 hrs)	59				
		change			○	○	○	○	○	every 500 hrs	71			
4	Hydraulic oil	check	Daily check						(every 10 hrs)	60				
		change				○		○	○	every 1000 hrs	73	*1		
5	Greasing	grease	Daily check						(every 10 hrs)	60				
6	Radiator and oil cooler	check	Daily check						(every 10 hrs)	61				
7	Engine and electrical wiring	check	Daily check						(every 10 hrs)	61				
8	Water separator	drain	Daily check						(every 10 hrs)	61				
9	Washer liquid	check	Daily check						(every 10 hrs)	62				
10	Fuel tank	drain	○	○	○	○	○	○	○	every 50 hrs	65			
11	Track tension	check	○	○	○	○	○	○	○	every 50 hrs	65			
12	Battery condition	check	Daily check						(every 10 hrs)	63				
13	V-belt tension	check	Daily check						(every 10 hrs)	61				
		adjust		○	○	○	○	○	○	every 250 hrs	68			
14	Dust indicator	Check	Daily check						(every 10 hrs)	62				
15	Radiator hoses and clamps	check		○	○	○	○	○	○	every 250 hrs	67			
		replace								every 2 years	78			
16	Inside of main frame	clean		○	○	○	○	○	○	every 250 hrs	69			
17	Air cleaner element	Outer element	clean	○	○	○	○	○	○	○	every 50 hrs	66	*2	@
		replace		○	○	○	○	○	○	○	every 250 hrs	69	*2	
		Inner element	replace		○	○	○	○	○	○	every 250 hrs	69	*2	
18	Fuel filter cartridge	replace			○	○	○	○	○	every 500 hrs	72		@	
19	Engine oil filter cartridge	replace			○	○	○	○	○	every 500 hrs	71			

No.	Check points	Measures	Hour meter indicator							Interval	Ref. page			
			50	250	500	1000	1500	2000	3000					
20	Drive unit oil	change		●	○	○	○	○	○	○	every 500 hrs	72		
21	Breather filter	replace			○	○	○	○	○	○	every 500 hrs	73		
22	Hydraulic return filter	replace		●	○	○	○	○	○	○	every 500 hrs	73		
23	Hydraulic suction filter	replace				○		○	○		every 1000 hrs	73		
24	Hydraulic oil filter	replace	●		○	○	○	○	○	○	every 500 hrs	73		
25	Injector tip	check					○		○		every 1500 hrs	75	*3	@
26	Alternator and starter motor	check						○			every 2000 hrs	75		
27	Oil separator element	replace					○		○		every 1500 hrs	75		@
28	EGR cooler	check					○		○		every 1500 hrs	75	*3	@
29	EGR system	check							○		every 3000 hrs	75	*3	@
30	Turbo charger	check							○		every 3000 hrs	75	*3	@
31	DPF	clean							○		every 3000 hrs	75	*3	@
32	Radiator system	rinse									every 2 years	76		
33	Fuel line and intake air line	check		○	○	○	○	○	○	○	every 250 hrs	68		@
		replace									every 2 years	78		
34	Exhaust manifold (crack, gas, leakage and mounting screw)	check									every 1 year	76	*3	
35	Intake air line for air leaks	check									every 1 year	76	*3	
36	Boost sensor and AFS (Air flow sensor)	check									every 1 year	76	*3	
37	Condition of DPF muffler	check									every 1 year	76	*3	
38	DPF differential pressure sensor and piping for gas leak	check									every 1 year	76	*3	
39	DPF exhaust gas temperature sensor	check									every 1 year	76	*3	
40	EGR and piping for gas leak	check									every 1 year	76	*3	
41	Closed breather related rubber piping	replace									every 2 years	78	*3	
42	DPF differential pressure sensor rubber piping (Front and back)	replace									every 2 years	78	*3	
43	Suction pipe downstream the AFS (Air flow sensor)	replace									every 2 years	78	*3	
44	Boost sensor pressure rubber piping	replace									every 2 years	78	*3	
45	EGR cooler hose	replace									every 2 years	78	*3	

## ◆ Air-conditioner

No.	Check points	Measures	Hour meter indicator						Interval	Ref. page			
			50	250	500	1000	1500	2000					3000
1	Air filter	clean		○	○	○	○	○	○	every 250 hrs	69	*2	
		replace				○		○	○	every 1000 hrs	-	*2	
2	Air-conditioner condenser	check		○	○	○	○	○	○	every 250 hrs	70		
3	Air-conditioner pipes and hose	check								every 1 year	76		
		replace								every 2 years	78		
4	Refrigerant (gas)	check								service as required	79		

**IMPORTANT :**

## ● First operation

\*1 When using a hydraulic hammer, change hydraulic oil and return filter according to the table on "Hydraulic Oil Change (Including Replacing of the Suction Filter and Return Filter in the Hydraulic Tank) "EVERY 1000 SERVICE HOURS" in "REGULAR CHECKS AND MAINTENANCE WORK" section.

\*2 Clean and replace the air cleaner element more frequently if used under dusty conditions. When the filter is very dirty from dusty conditions, replace the filter.

\*3 Consult your local KUBOTA dealer for this service.

● The items listed above (@ marked) are registered as emission related critical parts by KUBOTA in the U.S.EPA non-road emission regulation. As the engine owner, you are responsible for the performance of the required maintenance on the engine according to the above instruction. Please see the warranty Statement in detail.

# OPENING AND CLOSING OF COMPONENTS

## ■ Rear Door



### CAUTION

To avoid personal injury:

- When opening the rear door, open it firmly to the locked position.
- When opening and closing the rear door, be careful not to get your hands or other parts of your body caught.

### ◆ Opening

1. Pull the lever and open the rear door.
2. Insert the pin into the "LOCKED" position to fix the rear door.

### ◆ Closing

1. Be sure to close the engine hood before closing the rear door.
2. Support the rear door by hand, remove the pin from the "LOCKED" position and insert it into "ORIGINAL" position.
3. Close the rear door firmly until the lever is fully returned.



(1) Lever

(A) "PULL"

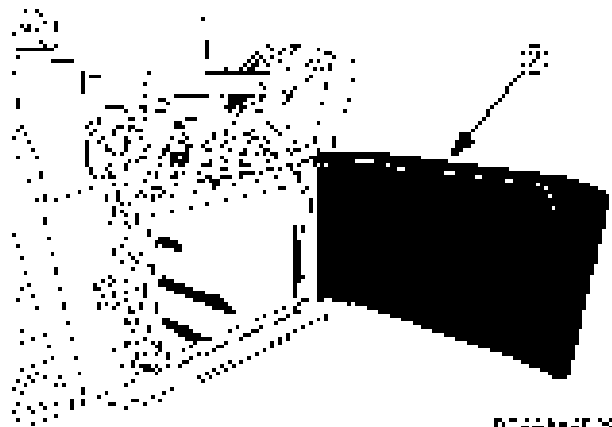

(2) Rear door

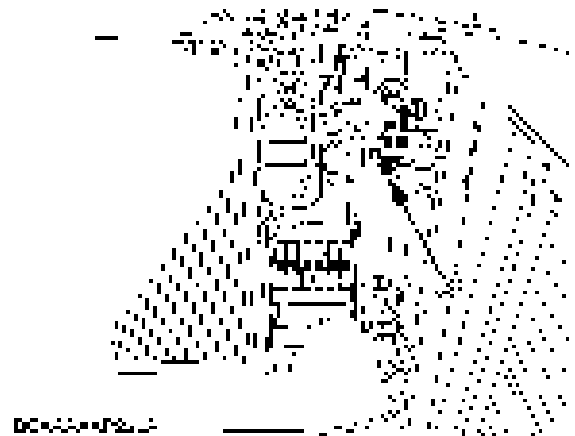

(3) Pin

(A) "ORIGINAL" position  
(B) "LOCKED" position

■ Engine Hood

**CAUTION**

To avoid personal injury from contact with moving parts:

- Never open the engine cover while the engine is running.
- Do not touch muffler or exhaust pipes while they are hot; Severe burns could result.
- When opening and closing the engine hood, be careful not to get your hands pinched or other parts of your body caught.

1. Hold up the engine hood and fix it with the stay rod.



(1) Stay rod

■ Radiator and Oil Cooler

**CAUTION**

To avoid personal injury:

- Always stop the engine and remove the key before checking the radiator and oil cooler.
- Wear eye protection when cleaning with compressed air.

1. Remove the four bolts and detach the radiator and oil cooler tilt stopper.  
At first pull the radiator and oil cooler backward (A) and tilt it down (B).

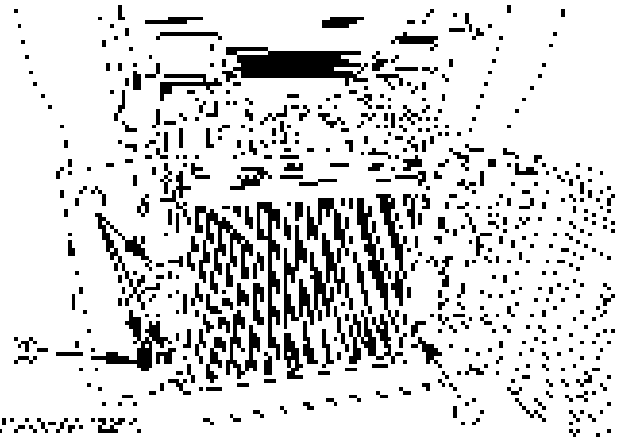

(1) Bolts  
(2) Radiator and oil cooler tilt stopper



(3) Radiator and oil cooler (A) "PULL BACKWARD" (B) "TILT DOWN"

**IMPORTANT :**

- Before tilting the radiator and oil cooler, undo the radiator hose from the stay. Before positioning them back in place, secure the radiator hose to the stay so that the hose does not get caught between the shroud and engine.



(1) Radiator hose  
(2) Stay

2. Place the radiator and oil cooler tilt stopper to prevent the tilted radiator and oil cooler from falling forward.



(1) Radiator and oil cooler tilt stopper

**Where to Keep Operator's Manual**

Keep the operator's manual in the operator's manual storage box at the back of the operator's seat.



(1) Operator's manual storage box  
(2) Storage space

**Tool Box**

1. Detach the floor mat.
2. Remove the nuts and detach the cover.



(1) Floor mat

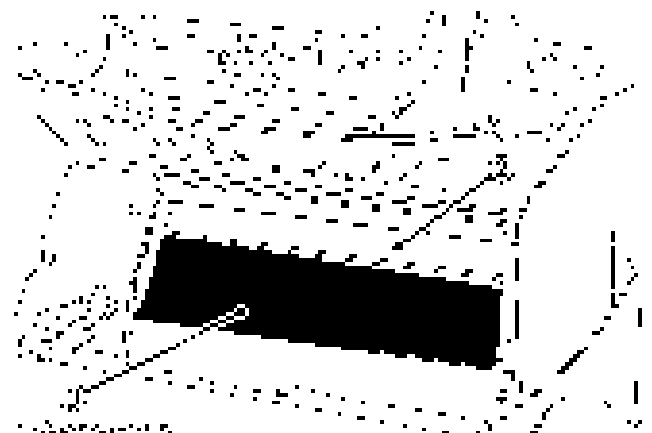

(2) Cover  
(3) Tool storage space

### ■ Tilting Up the CAB

For inspection and maintenance, the CAB is designed so that it can be tilted up.

### ⚠ WARNING

To avoid personal injury or death:

- Raising or lowering the cab while the engine is running may cause the machine to move, and cause personal injury or death. Place the machine on a firm, flat and level surface, lower the lift arms slowly to the ground and stop the engine before raising or lowering the cab.
- When the cab is tilted up, support it firmly with the stopper pin to prevent it from falling.
- Do not enter beneath the cab, while raising or lowering the cab.
- More than one person may be needed to tilt the cab.

### ◆ Raising (Tilt up)

1. Select a firm, level surface, lower the lift arms fully to the ground, and stop the engine.
2. Set the armrest to the "RAISED" position.
3. Remove the stopper pin from rear of the machine and remove the lock bolts from the front of the machine.



(1) Lock bolt

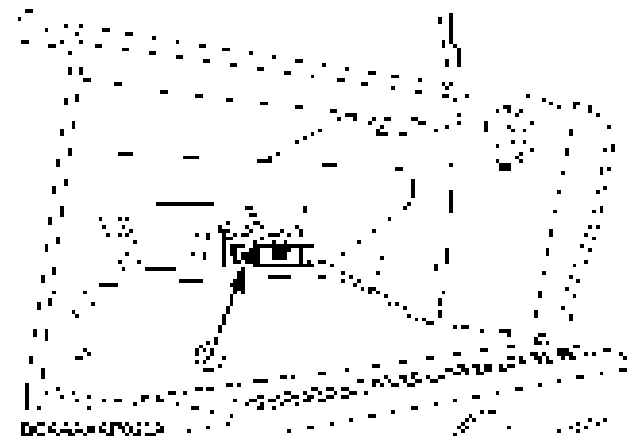

(2) Stopper pin

4. Slowly raise the cab until the cab is all the way up and the latching mechanism engages.

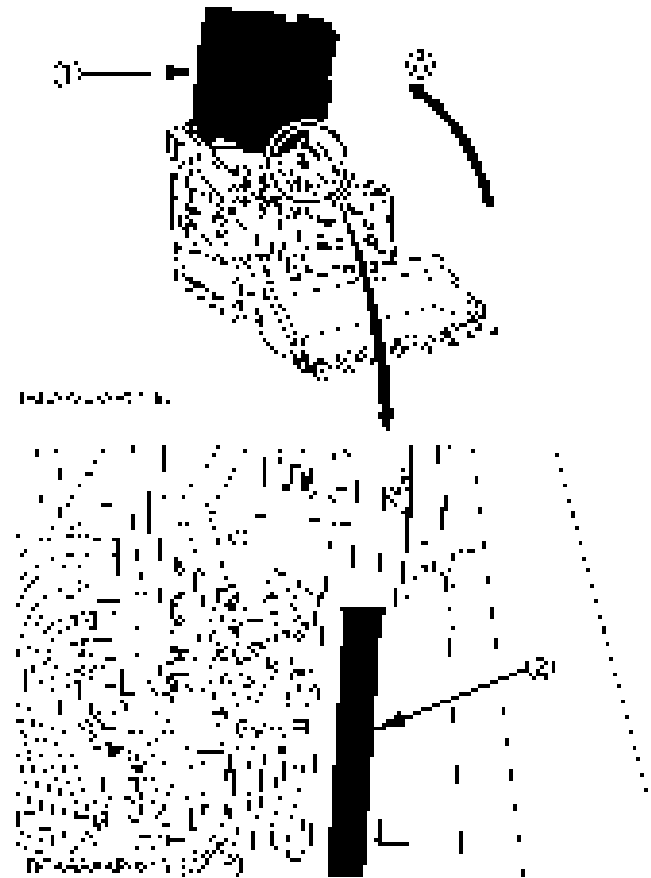

(1) Cab  
(2) Latching mechanism

(A) "RAISE"

5. Insert the stopper pin into the locked position to fix the cab.

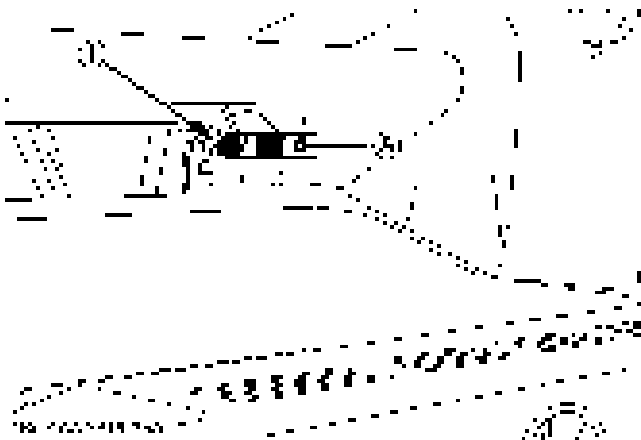

(1) Stopper pin

(A) "LOCKED" position

◆ Lowering (Tilt down)

1. Remove the stopper pin.
2. Support the cab and release the latching mechanism.
3. Lower the cab slowly all the way down.
4. Tighten the lock bolts with correct tightening torque and reinsert the stopper pin into the storage position.



(1) Latching mechanism

(A) "RELEASE" position



(2) Lock bolt

◆ Tightening torque:

77.5 to 90.2 N-m (57.2 to 66.5 ft-lbs)



(3) Stopper pin

(A) "STORAGE" position

## DISCHARGING MUD FROM OPERATOR ROOM AND MAIN FRAME

### ■ Operator room

1. Remove the floor mud outlet.
2. Discharge mud on the floor to the hole.

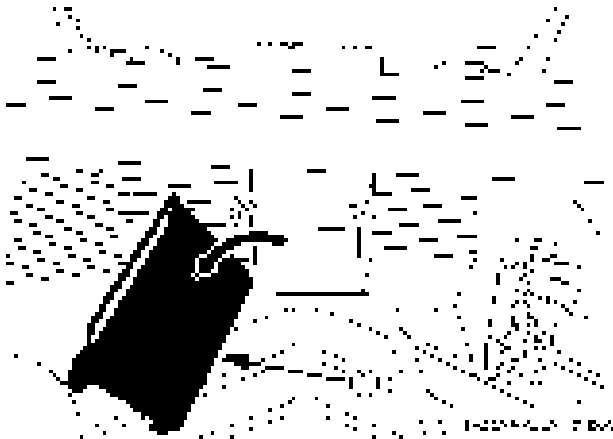

(1) Floor mud outlet (A) Remove

### ■ Main Frame

#### CAUTION

To avoid personal injury:

- Before diving under the machine, look around the surroundings, make sure of the safety and remove the key.
- The plate of the bottom of the main frame gets heavy with accumulated mud. In case it suddenly falls, do not be under the plate and remove with much care.

1. Tilt the CAB.
2. Open the rear door and tilt the radiator.
3. Open the plates of the bottom of the main frame.
4. Discharge mud on the main frame to the hole.

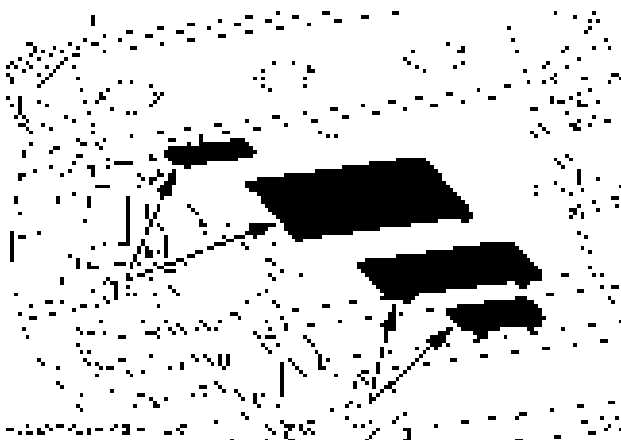

(1) Plates

## DAILY CHECKS

For your own safety and to assure the long life of your machine, a careful check should be made before each operation.

### ■ Checking Coolant Level

For your own safety and to assure the long life of your machine, a careful check should be made before each operation.

#### CAUTION

To avoid personal injury:

- Place the machine on a firm, flat and level surface, lower the lift arms slowly to the ground and stop the engine.
- Do not open the radiator cap right after the engine has been stopped; Serious burns can occur from contact with escaping hot coolant fluid.
- Check the coolant level in the recovery tank only after the engine has cooled down.
- Remove the radiator cap only if absolutely necessary.

1. Check to see that the coolant level is between the "FULL" and "LOW" marks of recovery tank.
2. When the coolant level drops due to evaporation, add water only up to the full level.  
In case of leakage, add anti-freeze and water in the specified mixing ratio up to the full level.

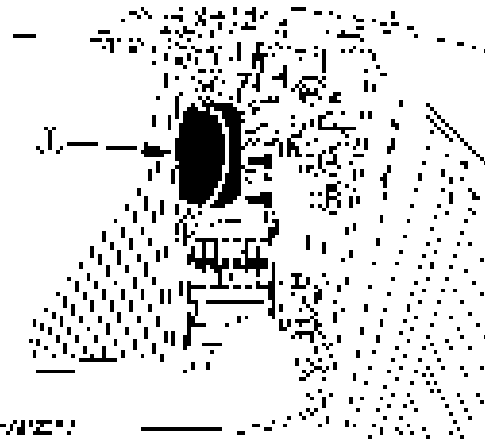

(1) Recovery tank (A) "FULL" (B) "LOW"

#### IMPORTANT :

- Do not fill the recovery tank over the "FULL" marking.
- Do not fill with dirty or salty water.

■ Checking Fuel Level

**CAUTION**

To avoid personal injury:

- Stop the engine and remove the key before fueling.
- Do not smoke while fueling.

**IMPORTANT :**

- By temperatures over -5°C (+23°F), use No.2-D diesel fuel, when temperatures are under -5°C (+23°F), use No.1-D diesel fuel.
- Make sure that the fuel tank will not run empty. Air will enter the fuel system, and must be purged before restarting engine.
- Be very attentive to the remaining fuel for the engine not to stall. If the engine stalls, it may fail to get restarted for a while to protect the emission purifying device.
- See "PURGING OF THE FUEL SYSTEM" in "OTHER ADJUSTMENTS AND REPLACEMENTS" section.
- To prevent condensation (water) accumulations in the fuel tank, fill the fuel tank full before parking overnight.

1. Turn the starter key to the "RUN" position.
2. Check the fuel level by the fuel level indicator.

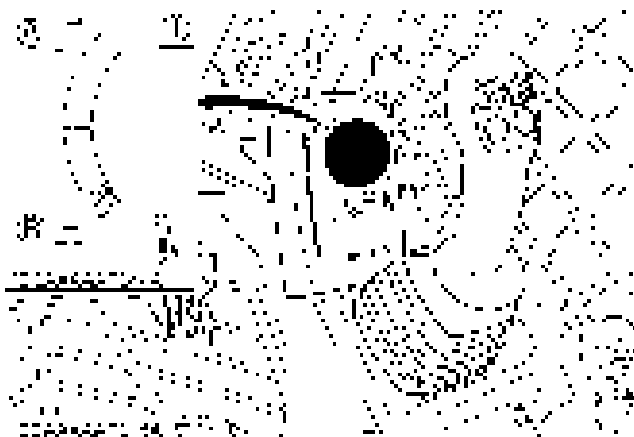

(1) Fuel gauge (A) "FULL" (B) "EMPTY"

3. If necessary, open the fuel tank cap with the starter key and fill the fuel. (See "Fuel Gauge Indicator" in "CHECK BEFORE START" section)

Fuel tank capacity	93 L (24.6 US gal)
--------------------	--------------------

■ Checking Engine Oil Level

**CAUTION**

To avoid personal injury:

- Stop the engine and remove the key before checking the oil level.

**IMPORTANT :**

- Use engine oil with the correct viscosity. (according to the outside temperature)
- After stopping the engine and remove the key, wait five minutes, then check oil level. (Machine must be on level ground.)
- Part of a small amount of fuel used for DPF-regeneration may get mixed with the engine oil, which will be more in volume than when initially poured. This is not a trouble.
- Do not attempt to repeat and interrupt the regeneration unnecessarily. By doing this, a small account of fuel comes into the engine oil, which will be degraded.

To check the oil level, draw out the dipstick, wipe it clean, replace it and draw it out again. Check to see that the oil level lies between the two notches.

If the level is too low, add new oil to the prescribed level at the oil filling port.



(1) Oil filling port (2) Engine oil dipstick (A) "Required oil level range"

### ■ Checking Hydraulic Oil Level

**CAUTION**

To avoid personal injury:

- Stop the engine and remove the key before checking the oil level.

**IMPORTANT :**

- Before filling oil, wipe away all sand and dust from around the oil port. Make sure to use an identical type of hydraulic fluid.
- The machine has been filled with hydraulic fluid before delivery. See "RECOMMENDED OILS" section. (Do not mix different oils.)

1. Park the machine on a firm, flat and level surface. Lower the lift arms slowly to the ground, tilt down the attachments and stop the engine.
2. Check the oil level as to whether it lies on the center of the gauge at normal temperature (10°C to 30°C (50°F to 86°F)).
3. Enough oil is present if the oil level lies near the center of the gauge.
4. Should the oil level be too low, fill up with oil through the oil port before starting the engine. This step is important for the protection of the hydraulic system.

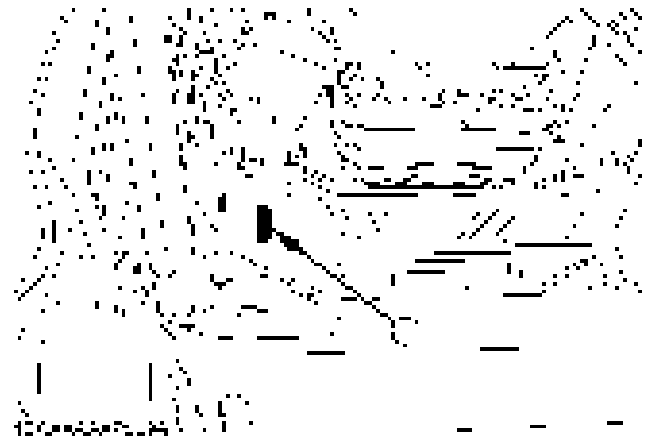

(1) Gauge

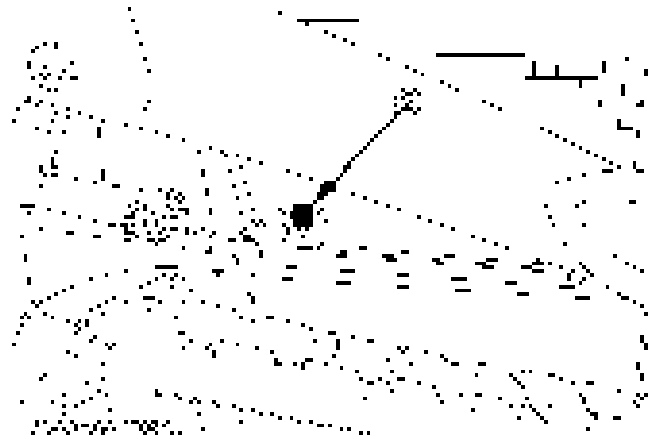

(2) Hydraulic tank cap (Oil filling port)

### ■ Lubrication Points

**CAUTION**

To avoid personal injury:

- First lower all attachments on the ground then stop the engine and remove the key.

**IMPORTANT :**

- When doing loader work in water, generously grease the following points. After ending work, grease again.

Grease the marked grease fittings (both sides) shown by arrows in the illustration below.

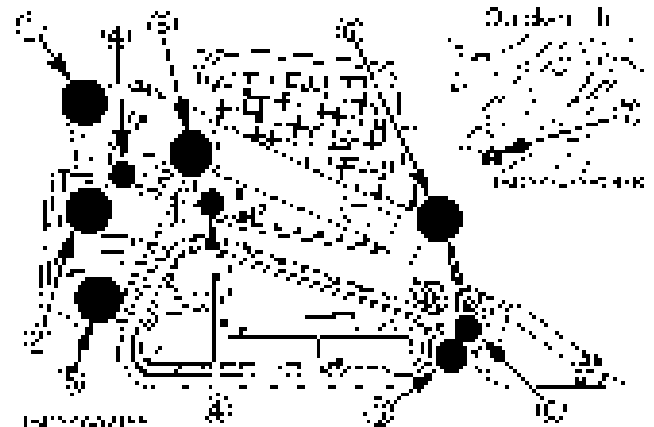

- |                                 |          |
|---------------------------------|----------|
| 1. Lift arm linkage .....       | 1 place  |
| 2. Link 1 .....                 | 1 place  |
| 3. Bucket link pin .....        | 1 place  |
| 4. Control link .....           | 2 places |
| 5. Lift arm cylinder boss ..... | 2 places |
| 6. Tilt cylinder boss .....     | 2 places |
| 7. Quick-hitch pin .....        | 1 place  |

### ■Checking Radiator and Oil Cooler

#### ⚠ CAUTION

To avoid personal injury:

- Always stop the engine and remove the key before checking the radiator and oil cooler.
- Wear eye protection when cleaning with compressed air.

1. Check if the fins and ribs are clogged. If so clean with compressed air or steam.
2. Check the rubber hoses for damage and replace if cracked or old. Check if the hose clamps are tight enough.

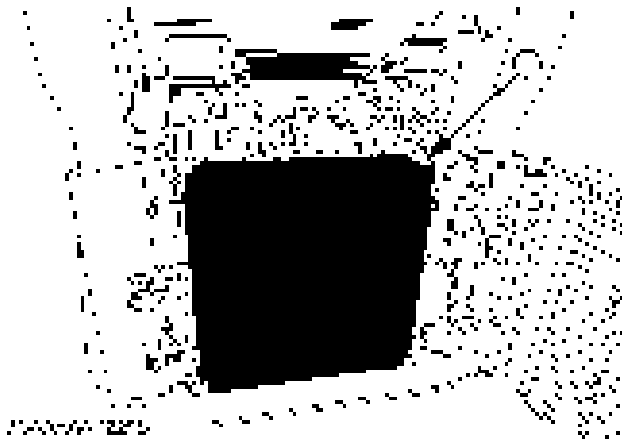

(1) Radiator and oil cooler

#### IMPORTANT :

- Radiator and oil cooler fins and ribs must be clean in order not to overheat the engine and allow free flow of air through the cooling elements.
- Pressure of compressed air must be under 205 kPa (2.1 kgf.cm<sup>2</sup>, 30 psi)
- When cleaning the radiator and oil cooler with compressed air, the fins can be damaged. Pay attention not to damage the fins.

### ■Checking and Cleaning Engine and Electrical Wiring

#### ⚠ CAUTION

To avoid personal injury:

- Always stop the engine and remove the key before cleaning the wiring, cables and engine.

Before starting, check whether flammable substances have gathered on the battery, the cables and wiring, the muffler or on the engine. Remove thoroughly. Check the electrical circuitry for disconnections, shorts or loose terminals.

### ■Checking V-belt

#### ⚠ CAUTION

To avoid personal injury:

- Stop the engine and remove the key before checking the V-belt.
- Check the V-belt for cracks and proper tension. (See "Adjusting V-belt Tension" in "REGULAR CHECKS AND MAINTENANCE WORK" section.)

### ■Washing Whole Machine

#### IMPORTANT :

- Do not wash the machine with the engine running. Water could enter the air cleaner and damage the engine. Make sure that the air cleaner is kept dry.
- Remove the mud before washing the machine.

### ■Draining Water Separator

1. Open the rear door.
2. When the separated water is entering the sediment cup, the red float moves upwards. If the float is one inch above the bottom, close the shutoff-valve so that no fuel can run out. Then loosen the drain plug and let out water until the float drops down to the bottom.
3. Finally, tighten the drain plug and turn the shutoff-valve back its original position.

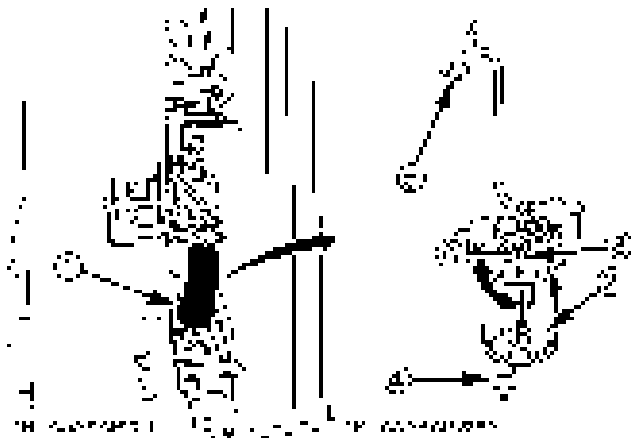

(1) Water separator

(2) Float

(3) Shutoff-valve

(4) Drain plug

(A) Close

(B) Open

### ■ Cleaning Evacuator Valve

Open the evacuator valve to get rid of large particles of dust and dirt.



(1) Evacuator valve

### ■ Checking Dust Indicator

There is a dust indicator on the air cleaner body. If the red signal on the dust indicator is visible, clean the element immediately. (See "Cleaning Air Cleaner Outer Element" in "EVERY 50 HOURS" in "REGULAR CHECKS AND MAINTENANCE WORK" section.) Reset the red signal by pushing a "RESET" button after cleaning.



(1) "RESET" button  
(2) Dust indicator  
(3) Red signal

### ■ Checking Diesel Particulate Filter (DPF) Muffler



#### CAUTION

To avoid personal injury:

- Before checking or cleaning the DPF muffler, stop the engine and wait long enough until it is cooled down.

Check to see if nothing flammable is deposited around the DPF muffler. Otherwise a fire may result.

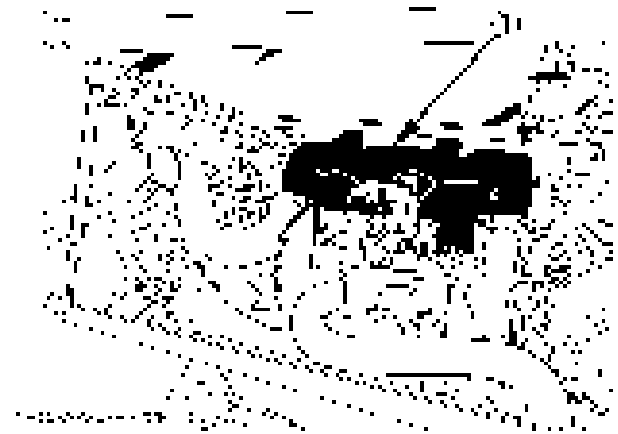

(1) DPF muffler

### ■ Checking Washer Liquid

If the windows washer is switched on with the washer liquid tank empty, the motor may be damaged. Always keep the tank filled.



(1) Washer liquid tank

#### IMPORTANT :

- Get the washer liquid tank half filled (about 0.8 liter) before working on a slope or a rough ground. The liquid may leak out when the machine bounces.

## ■ Checking Battery Condition



### DANGER

To avoid the possibility of a battery explosion:  
For refillable type battery, follow the instructions below.

- Do not use or charge the refillable type battery if the fluid level is below the LOWER (lower limit level) mark. Otherwise, the battery component parts may prematurely deteriorate, which may shorten the battery's service life or cause an explosion. Check the fluid level regularly and add distilled water as required so that the fluid level is between the UPPER and LOWER levels.



### CAUTION

To avoid personal injury:

- Never remove the vent caps while the engine is running.
- Keep electrolyte away from eyes, hands and clothes. If you are splattered with it, wash it away completely with water immediately and get medical attention.
- Wear eye protection and rubber gloves when working around the battery.
- Before inspection or dismantling the battery, be sure to turn off the engine and turn the starter switch to the "OFF" position.
- When removing the battery, always disconnect the negative ground cable first. When installing a battery, always connect the ground cable last. This prevents a possible explosion caused by sparks.
- Always wear eye protection when working with the battery.

**The factory-installed battery is of non-refillable type. If the indicator turns white, do not quick charge the battery but replace it with new one.**

Mishandling the battery shortens the service life and adds to maintenance costs.

The original battery is maintenance free, but needs some servicing.

If the battery is weak, the engine will be difficult to start and the lights will be dim. It is important to check the battery periodically.



- (1) Battery
- (2) Indicator

#### ◆ How to read the indicator

Check the battery condition by reading the indicator.

State of indicator display	
Green	Specific gravity of electrolyte and quality of electrolyte are both in good condition.
Black	Needs charging battery.
White	Needs replacing battery.

◆ **Battery Charging**



**WARNING**

To avoid personal injury or death:

- When the battery is being activated, hydrogen and oxygen gases in the battery are extremely explosive. Keep open sparks and flames away from the battery at all times, especially when charging the battery.
- When charging the battery, ensure the vent caps are securely in place. (if equipped)
- When disconnecting the cable from the battery, start with the negative terminal first. When connecting the cable to the battery, start with the positive terminal first.
- Never check battery charge by placing a metal object across the posts. Use a voltmeter or hydrometer.



(1) Battery

1. To slow charge the battery, connect the battery positive terminal to the charger positive terminal and the negative to the negative, then recharge in the standard fashion.
2. A boost charge is only for emergencies. It will partially charge the battery at a high rate and in a short time. When using a boost-charged battery, it is necessary to recharge the battery as early as possible. Failure to do this will shorten the battery's service life.
3. The battery is charged if the indicator display turns green from black.
4. When exchanging an old battery for a new one, a battery of equal specification.

Battery Type	Volts (V)	Capacity
GP31(105E41R)	12	85.3 (at 5H.R(A.H))

Battery Type	Reserve Capacity (min)	Cold Cranking Amps	Normal Charging Rate (A)
GP31(105E41R)	160	900	11

◆ **Direction for Storage**

1. When storing the machine for long periods of time, remove the battery from machine, adjust the electrolyte to the proper level and store in a dry place out of direct sunlight.
2. The battery self-discharges while it is stored. Recharge it once every three months in hot seasons and once every six months in cold seasons.

# REGULAR CHECKS AND MAINTENANCE WORK



## CAUTION

To avoid personal injury:

- Before doing maintenance work on the machine, place the machine on a firm, flat and level surface, lower the lift arms slowly to the ground, stop the engine.

## EVERY 50 SERVICE HOURS

### ■ Draining the Water from the Fuel Tank



## CAUTION

To avoid personal injury:

- Before draining the water from the fuel tank, be sure to stop the engine and remove the key.
- Do not smoke during inspection.

1. Open the cover.
2. Open the drain shutoff-valve.

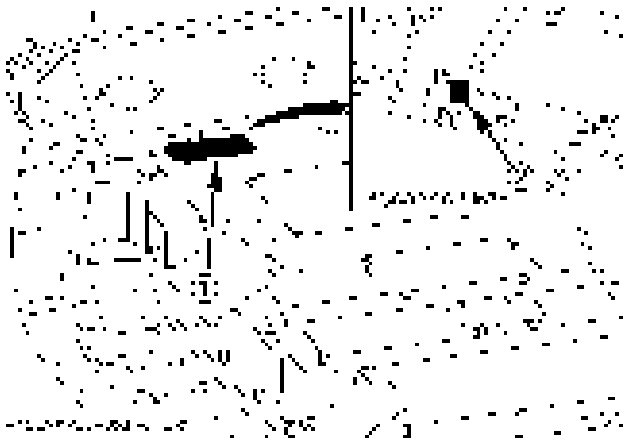

- (1) Cover
- (2) Drain shutoff-valve

### ■ Checking Track Tension

1. To check the track tension, put the machine on the jackstand. The track must be lifted from the ground as shown. The track tension is correct if the distance (A) (clearance between the outer end of the track roller and the track interior surface) corresponds to the dimension specified in the table below.



## DANGER

To avoid personal injury or death:

- Do not work under the machine in this condition.
- For your safety do not rely on hydraulically supported devices, they may leak down and suddenly drop or be accidentally lowered.



## WARNING

To avoid personal injury or death:

- When lifting the machine itself with an attachment, place the jack stands under the main frame to prevent the machine from turning over.

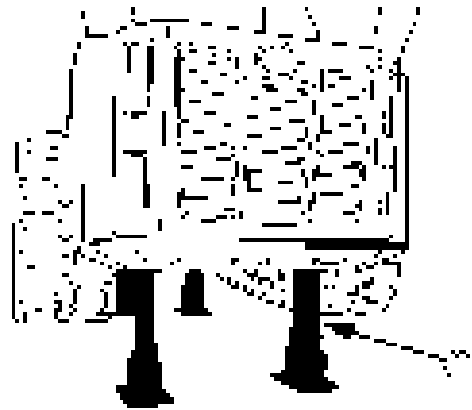

12/0000071-4

- (1) Jack stand

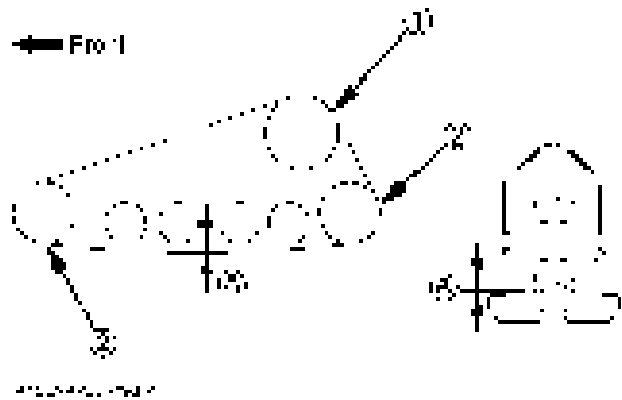

- (1) Drive sprocket
- (2) Idler

2. If necessary, adjust the tension.

(A)	20 to 30 mm (0.8 to 1.2 in.)
-----	------------------------------

**IMPORTANT :**

- Make sure that no obstacles, such as stones are caught in the track. Remove such obstacles before adjusting the track tension. (See "ADJUSTMENT OF TRACKS" in "OTHER ADJUSTMENTS AND REPLACEMENTS" section.)

**■ Inspection and Cleaning Air Cleaner Element**

Open the rear door and remove the dust-cover. Take out only outer element, clean the element, case interior and reassemble. During reassembly, take care to install the dust-cover so that its TOP mark (arrow) faces up-wards. Do not remove the inner element.

**IMPORTANT :**

- Should the machine be used in extremely dusty areas, the air cleaner element must be inspected and cleaned more frequently than in the specified maintenance periods.
- The air cleaner has a dry element, keep free from oil.
- Do not run the engine without the air cleaner.



- (1) Inner element
- (2) Outer element
- (3) Dust-cover
- (4) Clamps

**■ Air Cleaner Element**

**⚠ CAUTION**  
 To avoid personal injury:  
 ● Wear eye protection.

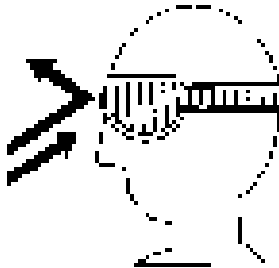

The quickest and safest method of maintenance is the exchange of the element. Furthermore there are different methods of cleaning the element.

**◆ Cleaning with compressed air**

Pressure of compressed air must be under 205 kPa (2.1 kgf/cm<sup>2</sup>, 30 psi), and the element should be blown clean from the inside to the outside until the dust deposits are noticeably reduced.



**IMPORTANT :**

- If the air suction is still inadequate, or the color of the exhaust gases is abnormal even after the cleaning, the air cleaner element must be replaced.
- Clean the air cleaner element regularly or foreign matters will be accumulated, which will make the DPF clogged for a shorter time than expected and the cleaning interval of the DPF (3000 hours) can't be secured.

**EVERY 250 SERVICE HOURS**

Do all 50 hour servicing at the same time.

**■ Checking Radiator Hoses and Clamps**

**⚠ CAUTION**  
 To avoid personal injury:  
 ● Wait long enough for the radiator coolant to cool down.

Check the water hoses for proper connection. This check should be carried out every 250 hours or every 6 months, whichever comes first.

1. Tilt the radiator.
2. Should the hose clamps become loose or water leaks, tighten the hose clamps properly.
3. Should the radiator hoses become swollen, aged or cracked, they must be replaced and the hose clamps tightened again properly.



(1) Radiator hose  
 (2) Hose clamps



(1) Radiator hose  
 (2) Hose clamps

**■Checking Fuel Line and Intake Air Line**

1. Check to see that all lines and hose clamps are tightened and not damaged.
2. If hoses and clamps are found worn or damaged, replace or repair them at once.



(1) Fuel lines



(1) Hose  
(2) Hose clamps

**■Adjusting V-belt Tension**



**CAUTION**

To avoid personal injury:

- First stop the engine and remove the key.
- After servicing, make sure to replace the belt cover in its original position.

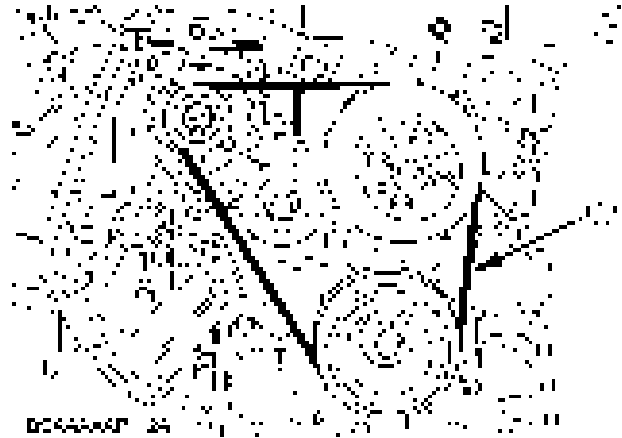

(1) V-belt

**◆ Checking and adjustment of the V-belt tension**

1. Press the V-belt (5) down in the middle, with a force of approx. 50 to 60 N (11.0 to 13.5 lbs). The belt tension is correct if it deflects about 4.0 to 5.0 mm (0.16 to 0.20 in.). If otherwise, loosen bolt (1), (2) and (3) and shift the alternator (4) in the direction shown by the arrow. After adjustment of the V-belt tension, tighten all the bolts.
2. Replace the V-belt if worn out, cracked or torn.

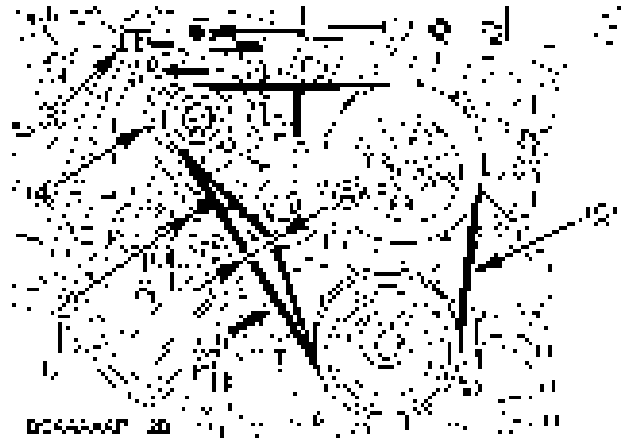

(1) Bolt (A) about 4.0 to 5.0 mm (0.16 to 0.20 in.)  
 (2) Bolt (B) approx. 50 to 60 N (11.0 to 13.5 lbs.)  
 (3) Adjuster bolt  
 (4) Alternator  
 (5) V-belt

**IMPORTANT :**

- If the engine is run with a loose alternator belt, the belt could slip and cause insufficient battery charging. Check V-belt tension regularly.
- Should the alternator belt break or jump off, the indicator light for battery charge will light up. Stop the engine and remove the key immediately.

◆ **Checking and adjustment of the air-conditioner belt tension [Closed cab model]**

1. Press the air-conditioner belt down in the middle, with a force of approx. 50 to 60 N (11.0 to 13.5 lbs). The belt tension is correct if it deflects about 7 to 9 mm (0.27 to 0.35 in.). If otherwise, loosen bolt of the tension pulley and shift the tension pulley in the direction shown by the arrow.
2. Replace the air-conditioner belt if worn out, cracked or torn.

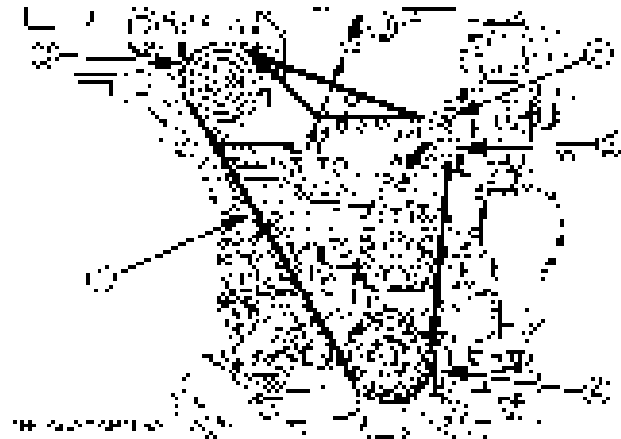

- |                                |                        |
|--------------------------------|------------------------|
| (1) Air-conditioner belt       | (A) about 7 to 9 mm    |
| (2) Tension pulley             | (0.27 to 0.35 in.)     |
| (3) Air-conditioner compressor | (B) approx. 50 to 60 N |
| (4) Pulley                     | (11.0 to 13.5 lbs.)    |
| (5) Bolt                       |                        |

■ **Cleaning Inside of Main Frame**

If mud, leaves or any debris are accumulated inside of main frame, it may cause any parts damaged. Remove mud, leaves and any debris from the inside of the frame. Refer to page 58 for detail procedure.



- (1) Plate

■ **Replacing Air Cleaner Element**

Open the rear door and engine hood. Remove the dust-cover. Remove and replace the outer element and inner element with new elements. When reassembling, install the dust-cover so that its TOP mark (arrow) faces up-wards.



- (1) Inner element  
 (2) Outer element  
 (3) Dust-cover  
 (4) Clamps

**IMPORTANT :**

- Shorten the replacement period if the machine is used in dusty or sandy areas.
- Replace the air cleaner element regularly or foreign matters will be accumulated, which will make the DPF clogged for a shorter time than expected and the cleaning interval of the DPF (3000 hours) can't be secured.

■ **Cleaning Inner Air Filter**

Remove the inner filter, and blow air from the direction opposite to the filter's normal air flow. Pressure of compressed air must be under 205 kPa (2.1 kgf/cm<sup>2</sup>, 30 psi).



- (1) Inner air filter

**■Cleaning Air Fresh Filter**



To avoid personal injury:

- When removing and attaching the filter, apply parking brake, stop the engine and remove the key.

Remove the thumbscrews and pull out filter.

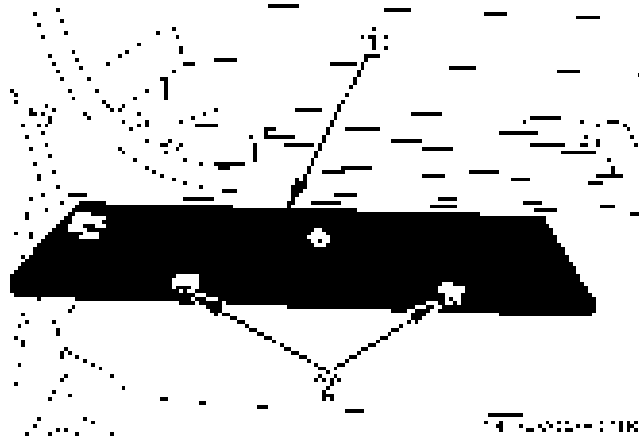

- (1) Cover
- (2) Thumbscrew

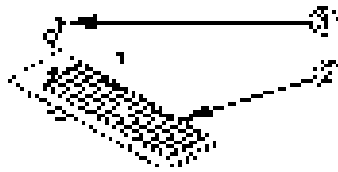

- (1) Fresh air filter
- (2) Cover
- (3) Thumbscrew

**NOTE :**

- Attach the filter and cover as the illustration above.

**◆ Cleaning the air filter**

- Normal use  
Blow air from the opposite direction to the filter's normal air flow.  
Pressure of compressed air must be under 205 kPa (2.1 kgf/cm<sup>2</sup>, 30 psi).

**IMPORTANT :**

- Do not hit the filter. If the filter becomes deformed, dust may enter into the air-conditioner, which may cause damage and malfunction.

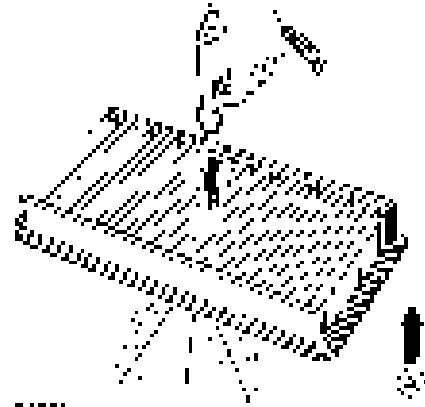

(A) "AIR CONDITIONER AIRFLOW"

**IMPORTANT :**

- Do not use gasoline, thinner or similar chemicals to clean the filter as damage to the filter may occur.
- It may also cause an unpleasant odor in the Cab when the system is used next.

**■Checking Air-Conditioner Condenser**

Check air-conditioner condenser to be sure it is clean from debris.



(1) Air-conditioner condenser

**NOTE :**

- Air flow from the outside to the inside so debris would accumulate on the outside. Outside cover might have to be removed to help clean.

## EVERY 500 SERVICE HOURS

Do all 50 and 250 hour servicing at the same time.

### ■ Changing Engine Oil



#### CAUTION

To avoid personal injury:

- First stop the engine then remove the key and wait long enough for the oil to cool down.

1. Remove the under cover on the bottom of the frame.
2. Remove the drain plug on the underside of the engine and drain all oil.
3. Re-tighten the drain plug, and attach the under cover.



- (1) Drain plug
- (2) Under cover

4. Fill up with new oil through the filling port to the specified level.

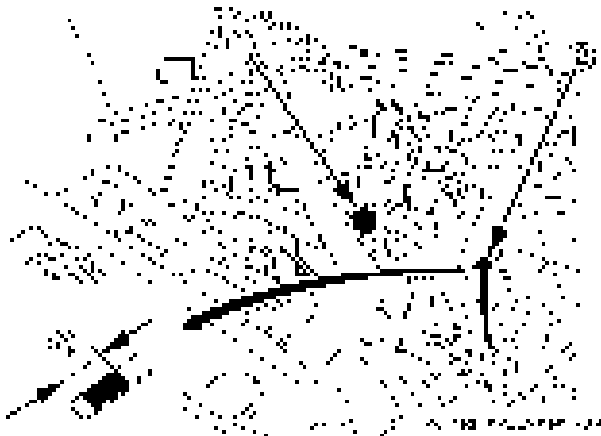

- (1) Oil filling port
  - (2) Engine oil dipstick
- (A) Required oil level range

Engine oil volumes  
(with engine oil filter)

10 L (2.6 US gal)

### ■ Replacing Engine Oil Filter Cartridge

1. Remove the under cover on the bottom of the frame (to drain the spilled oil from the engine oil filter cartridge).

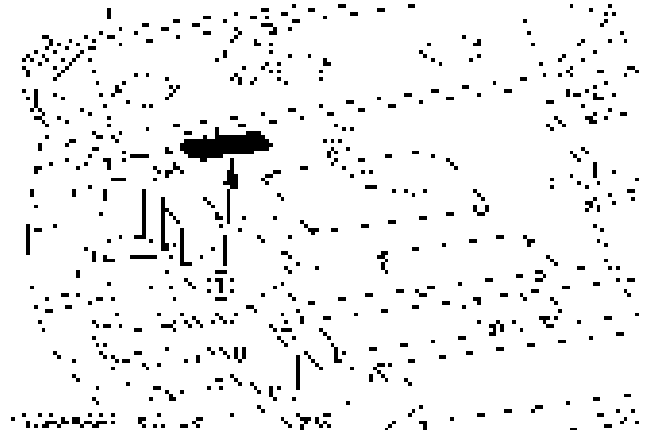

- (1) Under cover

2. Replace the oil filter cartridge at the same time as doing the engine oil change.
3. Remove the cartridge with the filter wrench.



- (1) Oil filter cartridge

4. Oil the O-ring of the new oil filter cartridge lightly. Then tighten the oil filter cartridge by hand.
5. Fill engine oil to the specified level.
6. Let the engine run for approx. 5 min. and make sure that the engine oil indicator lamp does not light up. Then stop the engine and remove the key.
7. The engine oil level is reduced by the amount of the filter capacity after the engine is started. It is necessary to add oil.
8. Attach the under cover.

#### IMPORTANT :

- Always check the oil level after having exchanged the filter.

**Replacing Fuel Filter Cartridge**

**CAUTION**  
 To avoid personal injury:  
 ● Keep fire away.

1. Tilt the radiator.
2. Remove the filter cartridge with the filter wrench.
3. Apply a small amount of fuel on the gasket of the replacement filter and by hand tighten it.



(1) Fuel filter cartridge

**IMPORTANT :**

- After exchange of the filter, the fuel system must be purged of air.
- If you don't replace the fuel filter cartridge regularly, the cleaning efficiency of the DPF (3000 hours) will be reduced and the DPF longevity will be shorter than expected.

**Changing Drive Unit Oil (First oil change: 250 hours)**

**CAUTION**  
 To avoid personal injury:  
 ● Lower the lift arms to the ground, stop the engine and remove the key before undertaking the oil change.

1. Rotate the track so that the drain plug of the drive unit is in the bottom position.
2. Remove the drain plug to let the oil run out. Screw in and tighten the drain plug again and fill with gear oil through the oil filling port.
3. Fill oil until it overflows out of the oil check port.
4. Use prescribed gear oil SAE 90.



(1) Oil filling port  
 (2) Drain plug  
 (3) Oil filling port

Gear oil volume	approx. 1.0 L (0.3 US gal.)
-----------------	--------------------------------

**Changing Return Filter (First filter change: 250 hours)**

See "Hydraulic Oil Change (Including Replacing of the Suction and Return Filter in the Hydraulic Tank)" in "EVERY 1000 SERVICE HOURS" in "REGULAR CHECKS AND MAINTENANCE WORK" section.

### ■ Replacing Breather Filter

The breather filter for the hydraulic tank is located above the hydraulic tank

1. Raise the cab. (See "Tilting Up the CAB" in "OPENING AND CLOSING OF COMPONENTS" in "MAINTENANCE" section for detail.)
2. Open the cap of the filter cover.
3. Remove the breather filter and replace with the new one.
4. Tighten the cap of the filter cover.



(1) Breather filter

### ■ Replacing Hydraulic Oil Filter (First filter change: 50 hours)

1. Raise the cab. (See "Tilting the CAB" in "OPENING AND CLOSING OF PARTS" in "MAINTENANCE" section for detail.)
2. Remove the hydraulic oil filter with the wrench and Replace with the new one.
3. Oil the O-ring of the new hydraulic filter cartridge lightly.  
Then tighten the hydraulic filter cartridge by hand.



(1) Hydraulic oil filter

## EVERY 1000 SERVICE HOURS

Do all 50, 250 and 500 hour servicing at the same time.

### ■ Hydraulic Oil Change (Including Replacing Suction and Return Filter in the Hydraulic Tank)



#### CAUTION

To avoid personal injury:

- Wait long enough for the hydraulic fluid to cool down. Then change the hydraulic fluid.

1. Park the machine on a firm, flat and level surface. Lower the lift arms to the ground and stop the engine.



(1) Firm, flat and level surface

2. Remove the cover with drain plug in front of the machine and drain the oil.



(1) Drain plug  
(2) Cover

3. Loosen the bolt and remove the tank cover.
4. Remove the suction filter. Replace the filter with new one.
5. Loosen the set bolt first and then remove the return filter. Replace the filter with new one.
6. Install the hydraulic cover.
7. Retighten the drain plug.

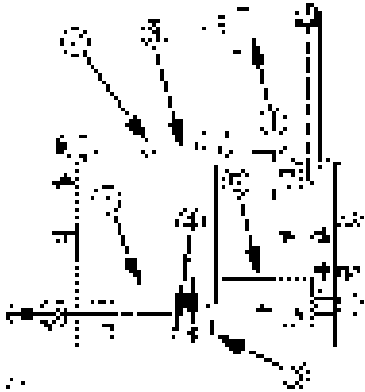

- |                     |                    |
|---------------------|--------------------|
| (1) Breather filter | (5) Return filter  |
| (2) Bolt            | (6) Filter stopper |
| (3) Cover           | (7) Suction filter |
| (4) Set bolt        |                    |

8. Fill oil through the oil filling opening on the top side of the tank pipe.
9. Let the engine run and operate the lift arm, bucket. Then lower the lift arms slowly to the ground, stop the engine.
10. Fill oil again up to the center of the gauge.

Hydraulic oil volumes	Hydraulic tank	35 L (9.3 US gal)
	Whole oil volumes	60 L (15.0 US gal)

11. Tighten the oil filling plug.

### ■ Hydraulic Oil Check with Hydraulic Hammers

The hydraulic oil change after 1000 operating hours in the operator's manual is based on normal work. Following inspection measures are valid when hydraulic hammers are used:

1. Changing and filling up of hydraulic oil
  - (1) The hydraulic oil must be changed more often when hammers are used because the machine is subject to harder conditions than normal work.
  - (2) Use only the recommended oils mentioned in the operator's manual when changing or filling with oil.
  - (3) When adding oil, do not mix oils of different makes.
2. Changing the return filter and oil
  - (1) The filter must be changed more often because of contamination resulting from the frequent assembly and disassembly of the hoses.
  - (2) Use the correct replacement filter.
  - (3) Oil change according to operating hours.

		Hydraulic oil	Return filter	Suction Filter
Normal work		every 1000 Hrs.	every 500 Hrs. (250 Hrs. after first operation)	every 1000 Hrs.
Hammer work portion	20%	every 800 Hrs.	every 300 Hrs.	
	40%	every 400 Hrs.		
	60%	every 300 Hrs.	every 100 Hrs.	
	more	every 200 Hrs.		

## EVERY 1500 SERVICE HOURS

Do all 50, 250 and 500 hour servicing at the same time.

### ■Checking Injector Tip

Consult your local KUBOTA Dealer for this service.

### ■Replacing Oil Separator Element



#### CAUTION

To avoid personal injury:

- Be sure to stop the engine before replacing the oil separator element.

1. Remove the cover and take out the element. Wipe off oil and the carbon in the case with a clean rag.
2. Fit a new oil separator element and new gasket.
3. Tighten the cover until a cover comes in contact with body.

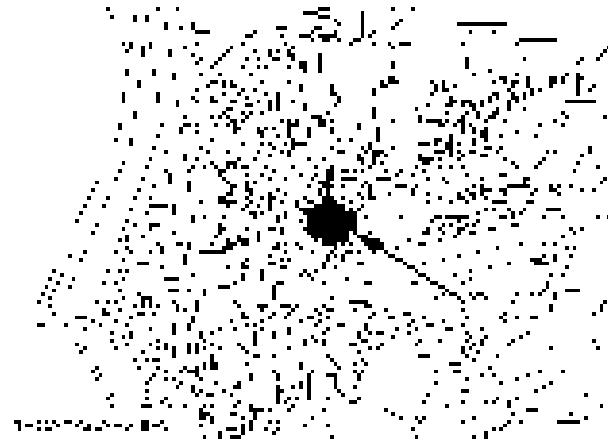

(1) Oil separator

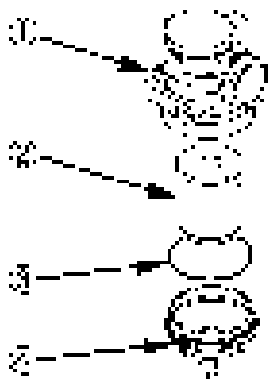

- (1) Body
- (2) Oil separator element
- (3) Gasket
- (4) Cover

### ■Checking EGR Cooler

Consult your local KUBOTA Dealer for this service.

## EVERY 2000 SERVICE HOURS

Do all 50, 250, 500 and 1000 hour servicing at the same time.

### ■Checking the Alternator and Starter Motor

NOTE :

- Contact your KUBOTA dealer for details.

## EVERY 3000 SERVICE HOURS

Do all 50, 250, 500, 1000 and 1500 hour servicing at the same time.

### ■Checking EGR System

Consult your local KUBOTA Dealer for this service.

### ■Checking Turbocharger

Consult your local KUBOTA Dealer for this service.

### ■Cleaning Diesel Particulate Filter (DPF)

The longer the DPF operates, the more ash (burnt residue) is collected in the filter. Too much ash build-up adversely affects the DPF performance. Consult your local KUBOTA Dealer to clean up the filter.

IMPORTANT :

- To clean up the DPF, a specific machine is required. Do not attempt to clean it in any other way, such as disassembling, shaking and heating as toxic chemicals may be present inside of the DPF.

## ANNUAL SERVICING

### ■ Checking Air-Conditioner Pipes and Hoses



#### CAUTION

To avoid personal injury:

- Do not touch the air-conditioner hoses or the heater with your hand. You may get burned.

1. Check to see that all lines and hose clamps are tight and not damaged.
2. If hoses and clamps are found worn or damaged, replace or repair them at once. (Consult your local KUBOTA Dealer for this service.)

### ■ Checking Exhaust Manifold (Cracks, Gas, Leakage and Mounting Screw)

Consult your local KUBOTA Dealer for this service.

### ■ Checking Intake Air Line for Air Leaks

Consult your local KUBOTA Dealer for this service.

### ■ Checking Boost Sensor and AFS (Air Flow Sensor)

Consult your local KUBOTA Dealer for this service.

### ■ Checking Condition of Diesel Particulate Filter (DPF) Muffler

Consult your local KUBOTA Dealer for this service.

### ■ Checking Diesel Particulate Filter (DPF) Differential Pressure Sensor and Piping for Gas Leak

Consult your local KUBOTA Dealer for this service.

### ■ Checking Diesel Particulate Filter (DPF) Exhaust Gas Temperature Sensor

Consult your local KUBOTA Dealer for this service.

### ■ Checking EGR Piping for Gas Leak

Consult your local KUBOTA Dealer for this service.

## BIENNIAL SERVICING

### ■ Changing Radiator Coolant



#### CAUTION

To avoid personal injury:

- When using anti-freeze, use protective clothing such as rubber gloves (Anti-freeze contains poison.).
- If anti-freeze has been swallowed, seek medical attention at once.
- When anti-freeze comes in contact with the skin or clothing, wash it off immediately.
- Do not mix different types of Anti-freeze. The mixture can produce a chemical reaction causing harmful substances or vapors.
- Anti-freeze is extremely flammable and explosive under certain conditions. Keep fire and children away from anti-freeze.
- When draining fluids from the engine, collect such with a some container underneath the engine body.
- Do not pour waste onto the grounds, down a drain, or into any water source.
- Also, observe the relevant environmental protection regulations when disposing of anti-freeze.
- Anti-freeze if swallowed is poisonous to people, animals and birds.

Park the machine on a firm, flat and level surface, lower the lift arms to the ground and stop the engine then remove the key and wait until it has cooled down completely.

1. Tilt the radiator.
2. Open the drain plug on the bottom of the radiator and drain coolant completely. Should a recovery tank be equipped, disconnect the line from the tank floor and then open the drain shutoff-valve.
3. To clean, rinse the radiator with water.
4. Close the drain plug and fill the radiator and the recovery tank with coolant fluid. Let the engine idle for about 5 min., stop the engine and remove the key.
5. Check the coolant level of recovery tank and add the coolant if necessary.
6. The machine has been shipped filled with 50% anti-freeze solution.

Cooling water	11 L (2.9 US gal.)
---------------	--------------------

**IMPORTANT :**

- Do not operate the engine without coolant.
- To fill the radiator system and the recovery tank, use fresh water and anti-freeze fluid.
- When the anti-freeze is mixed with water, the anti-freeze mixing ratio must be less than 50%.
- Tighten the radiator cap properly. If the cap is loosely or not properly fitted, overheating of the engine can result due to coolant fluid loss.

**■ Replacing Fuel Hose**

Replace the hoses and clamps.

(See "Checking Fuel and Intake Air Line" in EVERY 250 SERVICE HOURS" section.)



(1) Drain plug  
(2) Radiator cap



(1) Fuel lines

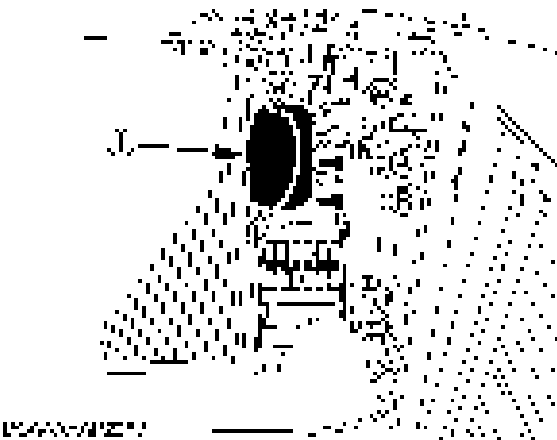

(1) Recovery tank  
(A) "FULL"  
(B) "LOW"

**■ Replacing Intake Air Line**

Replace the hose and clamps.  
 (See "Checking Fuel and Intake Air Line" in EVERY 250 SERVICE HOURS section.)



- (1) Hose
- (2) Hose clamps

**■ Replacement of Radiator Hoses**



**WARNING**

- To avoid personal injury or death:
- Replace radiator hoses and hose clamps every two years. If the hoses are swollen, hard or cracked, they must be replaced earlier.



- (1) Radiator hose
- (2) Hose clamps



- (1) Radiator hose
- (2) Hose clamps

**■ Replacing Air-Conditioner Pipes and Hoses**



**CAUTION**

To avoid personal injury:

- Do not touch the water hoses or the heater with your hand. You may get burned.

Replace air-conditioner pipes and hoses every two years. If the hoses or pipes are swollen, hard or cracked, they should be replaced. (Consult your local KUBOTA Dealer for this service.)

**■ Replacement of Closed Breather Related Rubber Piping**

Consult your local KUBOTA Dealer for this service.

**■ Replacement of Diesel Particulate Filter (DPF) Differential Pressure Sensor Rubber Piping (Front and Back)**

Consult your local KUBOTA Dealer for this service.

**■ Replacement of Suction pipe downstream the AFS (Air Flow Sensor)**

Consult your local KUBOTA Dealer for this service.

**■ Replacement of Boost Sensor Pressure Rubber Piping**

Consult your local KUBOTA Dealer for this service.

**■ Replacement of EGR Cooler Hose**

Consult your local KUBOTA Dealer for this service.

## SERVICING AS REQUIRED

### ■ Checking Amount of Refrigerant (gas)



#### WARNING

To avoid personal injury:

- Liquid contact with eyes or skin may cause frostbite.
- In the event of a leakage, wear safety goggles. Escaping refrigerant can cause severe injuries to eyes.
- In contact with a flame, R134a refrigerant gives a toxic gas.
- Do not disconnect any part of the refrigeration circuit of the air conditioning system. Consult your local KUBOTA Dealer for assistance and service.

A shortage of refrigerant reduces the air-conditioner performance. Check the following points. If it is indicated that the amount of refrigerant is extremely low, ask your dealer to inspect and charge.

#### ◆ Checking procedure

1. Run the air-conditioner in the following conditions.
  - Engine speed: About 1500 rpm
  - Temperature control lever: Maximum cooling position (rightmost)
  - Fan switch: Highest blow (3)
  - Air-conditioner switch: ON
2. Look into the sight glass to see if the refrigerant is flowing through its circuit.



Normal

The amount of refrigerant is normal.

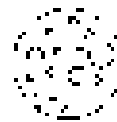

Low

The amount of refrigerant is low. Check the amount of refrigerant and charge if necessary.



Overfilled  
refrigerant

Check the amount of refrigerant.

34429-90124

#### IMPORTANT :

- Charge only with R134a not R12 refrigerant (gas).

### ■ Draining Water Separator

If the water separator error code (E:9120) appears on the meter panel, immediately drain the water separator. (For detail procedure, refer to page 61.)

#### IMPORTANT :

- If you don't drain the water separator immediately after the alarm, the engine may be seriously damaged.
- Without the water separator drained, the cleaning efficiency of the DPF (3000 hours) will be reduced and the DPF longevity will be shorter than expected.

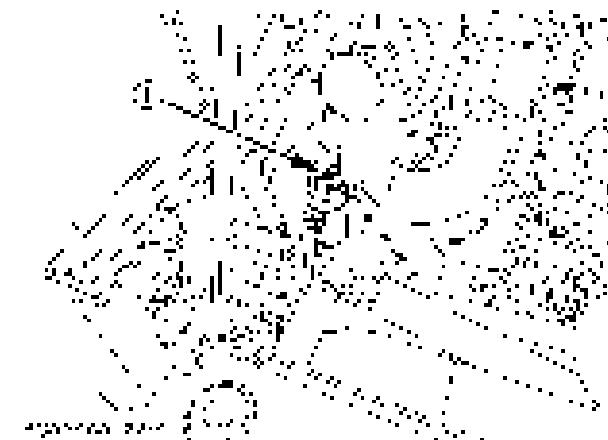

(1) Sight glass

# OTHER ADJUSTMENTS AND REPLACEMENTS

## PURGING OF THE FUEL SYSTEM

1. Fill up the machine with fuel.
2. Turn the starter key to the "RUN" position.
3. The air in the fuel system will automatically be purged within one minute.



- (1) Starter switch
- (A) "STOP"  
(B) "RUN"  
(C) "START"

### IMPORTANT :

- If the purging was insufficient, the engine dies right after starting. In this case repeat steps 2 to 3 again.

## ADJUSTMENT OF TRACKS

- ◆ To loosen the tracks, follow the following procedure:



### CAUTION

To avoid personal injury:

- Do not loosen the grease fitting completely or too quickly. Otherwise grease under high pressure in the tension cylinder could squirt out.
- Do not work under the machine.

1. Loosen the bolts and remove the cover.
2. Using a socket wrench, loosen the grease fitting a few turns.

### After adjustment is completed:

Using the socket wrench, tighten the grease fitting.

Tightening torque must be between 98 to 108 N·m (72.3 to 79.7 ft-lbs).

### IMPORTANT :

- If the tracks are too tight, wear is increased.
- If the tracks are too loose, the track pads may collide with the sprocket and wear is increased.  
The track may dislocate or come off.
- Clean the track after every use.

- Should the track tension be high due to sticking mud, remove mud from the track.

- ◆ To tension the tracks, follow the following procedure:

1. Loosen the bolt and remove the cover.
2. Apply grease into the grease fitting.

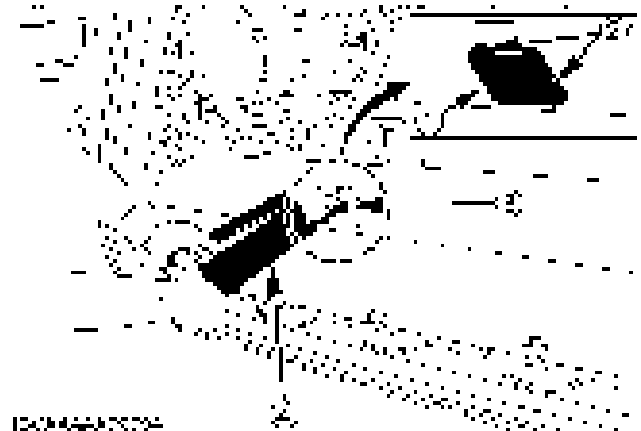

- (1) Cover  
(2) Bolt  
(3) Grease fitting  
(4) Grease gun

3. To check the track tension, put the machine on the jackstand. The track must be lifted from the ground as shown. The track tension is correct if the distance (A) (clearance between the outer end of the track roller and the track interior surface) corresponds to the dimension specified in the table below.



### DANGER

To avoid personal injury or death:

- Do not work under the machine in this condition.
- For your safety do not rely on hydraulically supported devices, they may leak down and suddenly drop or be accidentally lowered.

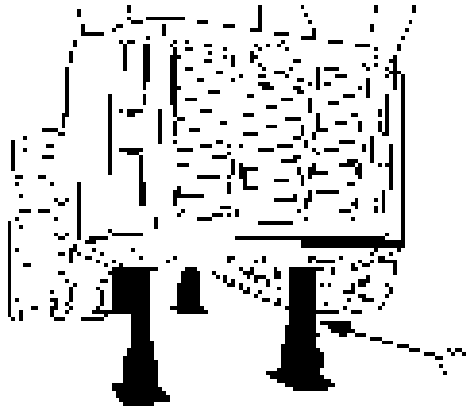

(1) Jack stand

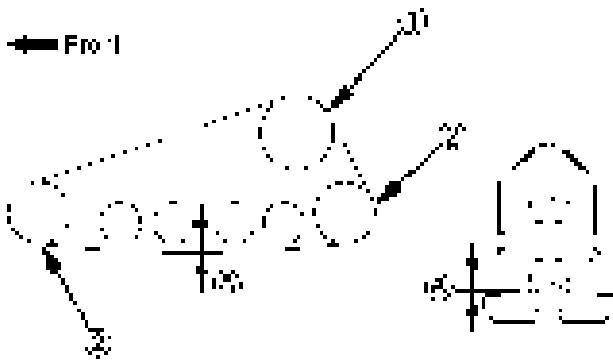

(1) Drive sprocket  
(2) Idler

(A)	20 to 30 mm (0.8 to 1.2 in.)
-----	------------------------------

**IMPORTANT :**

- Make sure that no obstacles, such as stones are caught in the track. Remove such obstacles before adjusting the track tension.

If the seam is positioned incorrectly, the tracks will be tensioned too loosely, and a further readjustment will be necessary.

- Rotate the track after adjustment one to two times to check the tension.
- Additionally following points are to be observed when adjusting rubber tracks.
  - (1) Check track tension 50 hours after initial use and readjust if necessary. Check and adjust thereafter every 50 service hours.

**FUSES**



**CAUTION**

To avoid personal injury:

- When changing fuse, stop the engine and turn the key in position "STOP". Keep the lock lever for attachment control in the "LOCK" position.

**Replacing Fuses**

1. Detach the cover and remove the cover of the fuse box.
2. Replace the burnt out fuse with a fuse having the same capacity.



(1) Cover  
(2) Fuse box

### ■ Fuse Capacities and Circuits

#### ■ [Open cab model]

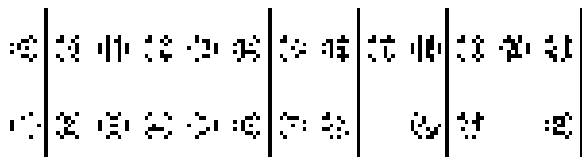

#### ■ [Closed cab model]

1	Room Light / Strobe Light [5A]	12	Fuel Pump [5A]
2	Front Work Lights [20A]	13	Control Elements [5A]
3	Rear Work Lights [15A]	14	Alternator [10A]
4	Horn [5A]	15	Arm Harness [20A]
5	Instrument Panel (+B) [5A]	16	Electrical Outlet [15A]
6	AUX Electrical Power [15A]	17	Attachments-1
7	ECU (+B) [5A]	18	Attachments-2 [20A]
8	Starter [5A]	19	Air Ride Seat [20A]
9	Engine Elements [5A]	20	Backup Alarm [5A]
10	Switch (AC) [5A]	21	Engine ECU(AC) [5A]
11	ECU (AC) [20A]		

#### ■ [Closed cab model]

22	Blower Motor [20A]	24	Compressor Clutch [10A]
23	Wiper [15A]		

#### NOTE :

- The fuse of No.17 is not set at the factory. When using the attachments -1, contact your KUBOTA dealer.

### ■ Electrical Outlet

Max power is less than 120 W.

If you need another auxiliary electric, contact your KUBOTA dealer for details.



(1) Electrical outlet

### ■ Slow Blow Fuse

Slow blow fuse is provided to protect the electrical circuits. If the fusible link is blown, check the electrical circuits for trouble and then replace with a new compatible slow blow fuse.



(1) Slow blow fuse A  
(2) Slow blow fuse B

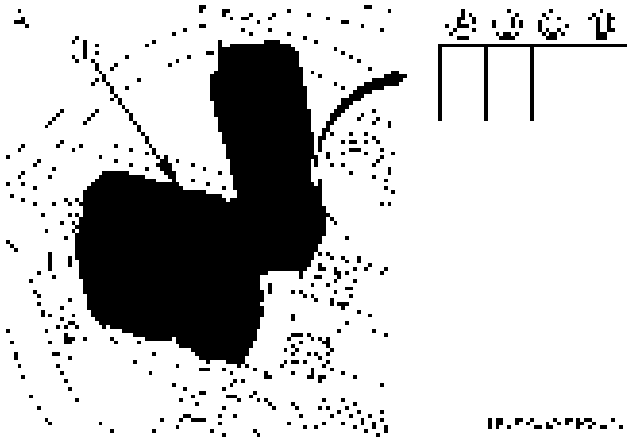

(1) Slow blow fuse A

**[Open cab model]**

	Protected circuit	Fuse type
(A)	Engine [30A]	Bolted
(B)	Main [60A]	Bolted
(C)	(Blank)	---
(D)	(Blank)	---

**[Closed cab model]**

	Protected circuit	Fuse type
(A)	Engine [30A]	Bolted
(B)	Main [60A]	Bolted
(C)	Closed cab [50A]	Plug-in
(D)	Condenser motor [20A]	Plug-in



(1) Slow blow fuse B

	Protected circuit	Fuse type
(A)	Glow plugs [60A]	Bolted
(B)	(Blank)	---
(C)	Alternator [100A]	Bolted

**◆ Replacement procedure**  
**[Bolted slow blow fuse]**

1. Disconnect the negative cord of the battery.
2. Remove the slow blow fuse case.



(1) Slow blow fuse case

3. Open the slow blow fuse case cap and cover then remove the bolts and draw out the bolted slow blow fuse.

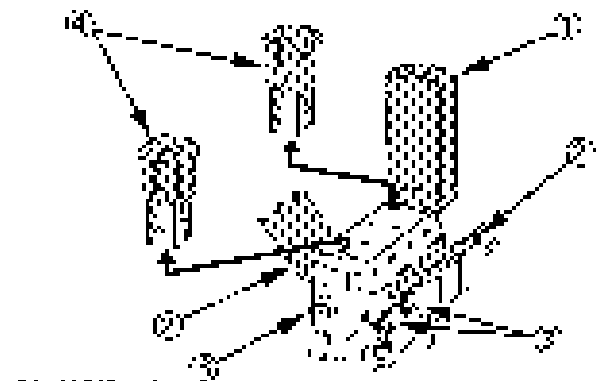
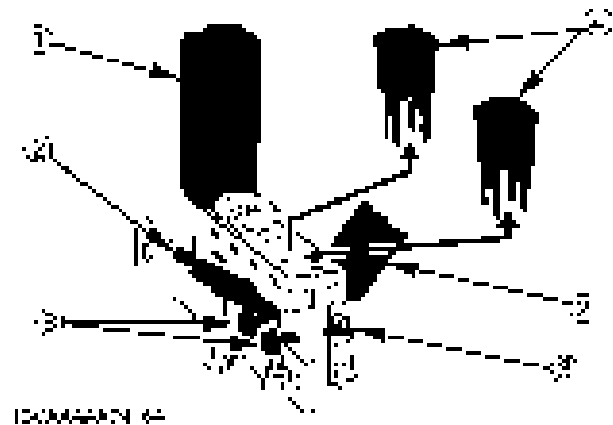

(1) Slow blow fuse case cap (3) Bolt  
(2) Cover (4) Bolted slow blow fuse

# TROUBLESHOOTING

If the machine does not show the desired performance, or when trouble arises, refer to the table below and undertake appropriate measures.

Trouble		Cause	Countermeasure
Engine	Starting difficulties	Fuel is too viscous.	* Check fuel tank and filter. * Remove impurities and water. * If necessary, replace filter.
		Air or water in the fuel system	* Remove water from the fuel tank. * Check fuel pipe joint bolts and nuts for looseness. * Purging of the fuel system (for fuel filter and supply pump, see "PURGING OF THE FUEL SYSTEM" in "OTHER ADJUSTMENTS AND REPLACEMENTS" section.)
		Fuse is blown out.	* Check the fuse and replace it with a same-capacity one as required.
		Oil viscosity is too high the engine runs sluggishly in winter.	* Use the engine block heater (option).
		Battery is almost dead; insufficient compression.	* Recharge battery.
	Insufficient engine power	Low fuel level	* Check fuel and add if necessary.
		Clogged air cleaner	* Clean the air cleaner element.
	Engine suddenly stops.	Low fuel level	* Check fuel and add if necessary. * Purge the fuel system.
	Abnormal exhaust gas color	Poor fuel	* Use high quality fuel.
		Too much engine oil	* Drain engine oil to prescribed oil level.
	Water temperature in red zone (Overheating)	Defective seal of the water pump	* Replace.
		Worn or torn V-belt	* Adjust or replace.
		Thermostat is defect.	* Replace.
		Coolant level too low	* Fill to prescribed level.
		Radiator grill or fins are clogged.	* Clean.
		Coolant is contaminated with rust from the cylinder head or crank case.	* Replace coolant fluid and add anti-rust.
		Defective radiator cap (Evaporation)	* Replace.
		Corroded coolant pipes	* Clean.
Continuous operation under full load		* Reduce load.	
Cylinder head gasket is damaged (Coolant loss).		* Replace.	
Engine oil level too low		* Fill to prescribed level.	
Maladjustment of fuel injection		* Readjust ignition timing.	
Use of poor fuel		* Use prescribed fuel.	

Trouble		Cause	Countermeasure
Hydraulic System	Lift arms, bucket, drive unite power is too low.	Hydraulic oil level too low	* Add oil.
		Leakages of hoses and / or joints	* Replace hose or joint.
		Armrest is in "Raised" position. Operator is not in the operator's seat. Hydraulic unlock lever is not pressed.	* Lower the armrests. * Sit in the operator's seat. * Press the hydraulic unlock switch.
Drive System	Deviation of drive direction	Blocked through stones	* Remove.
		Track too loose or too tight	* Adjust accordingly.
Electric system	"▲" mark appears in the instrument panel.	Electric system is malfunction.	* Check the error code number of next page and contact your local dealer.

## List of Error Code Numbers

☉ : Sure to happen    ☉ : May happen

Error Code Number	Problem or Failure	Machine condition				Provisional measure and Correction
		Engine performance			Machine performance	
		Acceleration limited	Engine output limited	Engine stopped		
E: 001	CAN communication	-	-	-	---	Immediately contact your local dealer.
E: 005	Hydraulic oil temperature has reached a specified level.	-	-	-	---	Stop the engine and check the level in the hydraulic oil tank and for a hydraulic oil leak. Fill to proper level. If this error code number still appears, immediately contact your local dealer.
E: 008	Fuel sensor system	-	-	-	The fuel level indicator does not appear on the meter. The machine's other functions are still operative.	Immediately contact your local dealer.
E: 009	Acceleration system	-	-	-	The accelerator fails, but the machine's other functions are still operative. The machine is operative at the idling rpm.	Move the machine to a place suited for repair. Immediately contact your local dealer.
E: 010	High-speed switching system	-	-	-	The machine still runs at low speed without switching to high speed. The machine's other functions are still operative.	Immediately contact your local dealer.
E: 011	Parking brake system	-	-	-	The machine fails to move.	Immediately contact your local dealer.
E: 012	Float switching system	-	-	-	The float mode is not turned on. The machine's other functions are still operative.	Immediately contact your local dealer.
E: 013	Hydraulic lock system	-	-	-	The attachment fails to function, but the machine can move.	Move the machine to a place suited for repair. Immediately contact your local dealer.
E: 015	Hydraulic quick-hitch system	-	-	-	The hydraulic quick-hitch system is not turned on. The machine's other functions are still operative.	Immediately contact your local dealer.
E: 016	Auxiliary hydraulic control system (Control switch on the knob)	-	-	-	The auxiliary hydraulic control system is not turned on. The machine's other functions are still operative.	Immediately contact your local dealer.
E: 018	Auxiliary hydraulic control system (Solenoid valve for Rightward SW)	-	-	-	The auxiliary hydraulic control system is not turned on. The machine's other functions are still operative.	Immediately contact your local dealer.

Error Code Number	Problem or Failure	Machine condition				Provisional measure and Correction
		Engine performance			Machine performance	
		Acceleration limited	Engine output limited	Engine stopped		
E: 019	Auxiliary hydraulic control system (Solenoid valve for Leftward SW)	-	-	-	The auxiliary hydraulic control system is not turned on. The machine's other functions are still operative.	Immediately contact your local dealer.
E: 020	Electronic Travel Torque Management System	-	-	-	The machine fails to move.	Immediately contact your local dealer.
E: 021	The sensor's 5V power supply is short-circuited.	-	-	-	The majority of systems fail. *The engine may be started and the machine may move. But do not try any jobs. (Just move the machine to a safe place.)	Immediately contact your local dealer.
E: 023	This error code number appears if a jumper cable is connected to a 24V battery or improper device to jump start the engine	-	-	-	Immediately stop using connected device and disconnect the 24V battery. When the engine gets restarted and is running with no error code number appearing, it means there is no problem.	If this error code number still appears, immediately contact your local dealer.
E: 026	CRS CAN communication	⊖	⊖	-	---	Immediately contact your local dealer.
E:9000	Requirement for DPF regeneration.	-	-	-	DPF must be regenerated, but low engine rpm is unable to start DPF regeneration.	Rev up the engine rpm and start DPF regeneration. If this error code number still appears, immediately contact your local dealer.
E:9001	Requirement for DPF regeneration.	-	⊙	⊖	DPF must be regenerated, but low engine rpm is unable to start DPF regeneration. If you leave the machine with the hydraulic locked, the engine can stop automatically.	Rev up the engine rpm and start DPF regeneration. If this error code number still appears, immediately contact your local dealer.
E:9002	DPF is regenerated.	-	⊙	-	---	---
E:9003	Requirement for DPF regeneration.	-	⊙	-	DPF must be regenerated, but unable to start regeneration.	Immediately contact your local dealer.
E:9004	Requirement for DPF replacement.	-	⊙	-	DPF must be replaced.	Immediately contact your local dealer.
E:9006	Requirement for DPF regeneration.	-	-	-	DPF must be regenerated, but unable to start regeneration because the inhibit switch is activated.	Move the machine to a safe place and release the inhibit switch to start DPF regeneration. If this error code number still appears, immediately contact your local dealer.

Error Code Number	Problem or Failure	Machine condition				Provisional measure and Correction
		Engine performance			Machine performance	
		Acceleration limited	Engine output limited	Engine stopped		
E:9007	Requirement for DPF regeneration.	-	⊙	○	DPF must be regenerated, but unable to start regeneration because the inhibited switch is activated. If you leave the machine with the hydraulic locked, the engine can stop automatically.	Restart the engine, move the machine to a safe place and release the inhibit switch to start DPF regeneration. If this error code number still appears, immediately contact your local dealer.
E:9010	Engine stop for DPF	-	-	⊙	The DPF regeneration fails to function. The machine is left with the hydraulic system locked, by which the engine stops itself.	Restart the engine, move the machine to a safe place and release the inhibit switch to start DPF regeneration. If this error code number still appears, immediately contact your local dealer.
E:9100	Rpm sensor system	○	○	-	---	Immediately contact your local dealer.
E:9101	Fuel or rail pressure system	⊙	⊙	⊙	---	Immediately contact your local dealer.
E:9102	SCV system	⊙	⊙	-	---	Immediately contact your local dealer.
E:9103	Intake air temperature sensor system	-	-	-	---	Immediately contact your local dealer.
E:9104	Coolant temperature system	⊙	⊙	-	---	Immediately contact your local dealer.
E:9105	Fuel temperature sensor system	-	-	-	---	Immediately contact your local dealer.
E:9106	Injector system	⊙	⊙	○	---	Immediately contact your local dealer.
E:9107	Intake air pressure sensor system	-	○	-	---	Immediately contact your local dealer.
E:9108	Battery voltage system	⊙	⊙	○	---	Immediately contact your local dealer.
E:9109	Sensor voltage system	⊙	⊙	○	---	Immediately contact your local dealer.
E:9110	Main relay system	-	-	-	---	Immediately contact your local dealer.
E:9112	Atmospheric pressure sensor system	-	○	-	---	Immediately contact your local dealer.
E:9113	EGR valve system	-	⊙	-	---	Immediately contact your local dealer.
E:9114	Emission level warning	-	-	-	---	For correction, refer to the Coolant Temperature Gauge section (page 15). If this error code number still appears, immediately contact your local dealer.

Error Code Number	Problem or Failure	Machine condition				Provisional measure and Correction
		Engine performance			Machine performance	
		Acceleration limited	Engine output limited	Engine stopped		
E:9115	Emission level caution	-	⊙	-	---	For correction, refer to the Coolant Temperature Gauge section (page 15). If this error code number still appears, immediately contact your local dealer.
E:9116	Engine overheat warning	⊙	-	-	---	For correction, refer to the Coolant Temperature Gauge section (page 15). If this error code number still appears, immediately contact your local dealer.
E:9117	Air heater system	-	-	-	---	Immediately contact your local dealer.
E:9118	Engine oil pressure system	-	-	-	---	Stop the engine and check the engine oil level. If this error code number still appears, immediately contact your local dealer.
E:9119	Charging system failure	-	-	-	---	Stop the engine and check the V-belt. If this error code number still appears, immediately contact your local dealer.
E:9120	Water separator warning	-	-	-	---	Stop the engine and check and drain the water separator. If this error code number still appears, immediately contact your local dealer.
E:9121	Engine ECU	⊙	⊙	⊙	---	Immediately contact your local dealer.
E:9122	ECU communication failure	⊙	⊙	-	---	Immediately contact your local dealer.
E:9200	Mass air flow sensor system	-	⊙	-	---	Immediately contact your local dealer.
E:9203	Intake air throttle	-	-	-	---	Immediately contact your local dealer.
E:9204	Differential pressure sensor system	-	-	-	---	Immediately contact your local dealer.
E:9205	Exhaust temperature sensor (DOC inlet)	-	-	-	---	Immediately contact your local dealer.
E:9206	Exhaust temperature sensor (DOC outlet)	-	-	-	---	Immediately contact your local dealer.
E:9207	Exhaust temperature sensor (DPF outlet)	-	-	-	---	Immediately contact your local dealer.
E:9208	All the exhaust temperature sensors break down at once.	-	-	-	---	Immediately contact your local dealer.
E:9211	DOC response is unusual.	⊙	⊙	-	---	Immediately contact your local dealer.

Error Code Number	Problem or Failure	Machine condition				Provisional measure and Correction
		Engine performance			Machine performance	
		Acceleration limited	Engine output limited	Engine stopped		
E:9212	DPF regeneration timeout	-	-	-	---	Immediately contact your local dealer.
E:9213	DPF regeneration Error (Water temperature is low)	-	-	-	---	Immediately contact your local dealer.
E:9214	DPF regeneration cycle occurs too often.	-	⊙	-	---	Immediately contact your local dealer.
E:9300	Engine fuel system (P/L)	⊙	⊙	-	---	Check the fuel level and see if the fuel filter is clogged. If this error code number still appears, immediately contact your local dealer.
E:9301	Engine fuel system (rail pressure)	⊙	⊙	-	---	Check the fuel level and see if the fuel filter is clogged. If this error code number still appears, immediately contact your local dealer.
E:9302	Engine fuel system (leakage)	⊙	⊙	-	---	Check the fuel level and see if the fuel filter is clogged. If this error code number still appears, immediately contact your local dealer.
E:9303	Engine fuel system (SCV)	⊙	⊙	-	---	Check the fuel level and see if the fuel filter is clogged. If this error code number still appears, immediately contact your local dealer.
E:9304	Engine fuel system (supply pump).	⊙	⊙	-	---	Check the fuel level and see if the fuel filter is clogged. If this error code number still appears, immediately contact your local dealer.
E:9305	Engine air intake system (poor air intake)	⊙	⊙	-	---	Check to see if any air-intake hose is disconnected and if the air cleaner element is clogged. If this error code number still appears, immediately contact your local dealer.
E:9306	Engine air intake system (boost pressure too low)	⊙	⊙	-	---	Check to see if any air-intake hose is disconnected and if the air cleaner element is clogged. If this error code number still appears, immediately contact your local dealer.
E:9307	Engine exhaust temperature (DOC inlet) is not as specified.	-	-	⊙	---	Check the fuel level and see if the fuel filter is clogged. Check to see if any air-intake hose is disconnected and if the air cleaner element is clogged. If this error code number still appears, immediately contact your local dealer.

Error Code Number	Problem or Failure	Machine condition				Provisional measure and Correction
		Engine performance			Machine performance	
		Acceleration limited	Engine output limited	Engine stopped		
E:9308	Engine exhaust temperature (DOC outlet) is not as specified.	-	-	⊙	---	Check the fuel level and see if the fuel filter is clogged. Check to see if any air-intake hose is disconnected and if the air cleaner element is clogged. If this error code number still appears, immediately contact your local dealer.
E:9309	Engine exhaust temperature (DPF outlet) is not as specified.	-	-	⊙	---	Check the fuel level and see if the fuel filter is clogged. Check to see if any air-intake hose is disconnected and if the air cleaner element is clogged. If this error code number still appears, immediately contact your local dealer.
E:9310	Starter turn-on limited	-	-	⊙	---	The starter is limited for its activation in response to any other error.
E:9400	Other failures	⊙	⊙	⊙	---	Immediately contact your local dealer.

# OPERATION UNDER COLD WEATHER CONDITIONS

## PREPARATION FOR OPERATION IN COLD WEATHER

1. Replace engine oil and hydraulic oil with those of viscosities suitable for cold weather.
2. In cold weather, battery power drops, and the battery fluid may freeze if the battery is not sufficiently charged. To prevent the battery fluid from freezing, be sure to keep the battery charged at least 80% or more of its capacity after operation. To ease next starting, it is recommended to keep the battery stored in closed or heated rooms.
3. Add anti-freeze to coolant in the radiator and recovery tank, if the ambient temperature is expected to drop below 0°C (32°F). Mixing ratio of water and anti-freeze depends on the expected ambient temperature. When mixing, stir it up well, and then fill into the radiator.

- Mixing ratio between water and anti-freeze

Ambient Temperature (°C / °F)	-5 (+23)	-10 (+14)	-15 (+5)	-20 (-4)	-25 (-13)	-30 (-22)	-35 (-31)
Antifreeze %	30	30	30	35	40	45	50
Water %	70	70	70	65	60	55	50

### IMPORTANT :

- Use permanent anti-freeze or long-life coolant.
- Drain the coolant completely and clean the inside of the radiator, then fill with the water and anti-freeze mixture.
- The anti-freeze acts as an anti-corrosive, it is not necessary to add an additive to the water and anti-freeze mixture.
- See "Checking coolant Level" in "DAILY CHECKS" in "MAINTENANCE" section for radiator fill volumes.
- See "STARTING THE ENGINE UNDER COLD CONDITIONS" in "OPERATION OF THE ENGINE" section.

## PROCEDURE AFTER COMPLETION WORK

Clean the machine thoroughly after work and wipe dry. Otherwise mud and earth on the tracks could freeze if the temperature drops below the 0°C (32°F). Operation of the machine is then not possible. Store the machine in a dry place; if not possible, store on wooden planks or on mats. If the machine is kept on damp or muddy ground, the tracks could freeze overnight. Operation of the machine is then not possible. Furthermore the reduction gear may be damaged.

Additionally, the piston rods of the hydraulic cylinders must be rubbed dry. Otherwise severe damage could occur if dirty water seeps through the seals.

# LONG STORAGE



## CAUTION

To avoid personal injury:

- Do not clean the machine with the engine running.
- To avoid the danger of exhaust fume poisoning, do not operate the engine in a closed building or any areas without proper ventilation.
- When storing, remove the key from the starter switch to avoid unauthorized persons from operating the machine and getting injured.
- Bring the machine on a firm, flat, and level surface. Lower the lift arms on the ground.

### ■ Should the Machine be Stored for a Longer Period of Time, Observe Following Procedures:

1. The whole machine should be cleaned thoroughly and in all cases stored indoors. If the machine has to be kept outdoors, lay out wooden planks on even ground, place the machine on the planks and cover completely.
2. Do an oil change and grease the machine.
3. Heavily grease the visible section of the cylinder rods.
4. Remove the battery and store indoors.
5. If it is expected that the temperature will sink below the 0°C (32°F), add anti-freeze or drain coolant completely.

### IMPORTANT :

- Wash the machine after stopping the engine.  
If you wash the machine while running the engine, splashing water gets into the air cleaner through its intake and cause engine damage.  
Carefully, wash and do not splash water over the air cleaner while the engine is running.

### ■ Observe Following Procedures when the Machine is to be Operated after Long Storage.

1. Wipe off the grease from the hydraulic cylinder rods.
2. Turn on the engine and operate the attachments and the drive mechanisms under no load in order to circulate the hydraulic oil.  
(If the machine is stored for longer than one month, do steps 1 and 2 once every month.)

**Periodic replacement of important component parts**

To ensure safety in operation, you are strongly requested to inspect and service the machine at regular intervals. For added safety, ask your KUBOTA dealer to replace the following important component parts.

These parts are prone to degradation in material or subject to wear and tear with time. It is difficult to judge how much they have been affected at regular inspection. It is therefore necessary to replace them with new ones, whether wear is visible or not after a specified time of use.

If any of them is found worn even before the specified use, it must be repaired or replaced the same way as other parts.

If any of the hose clamps is found deformed or cracked, the hose clamp must also be replaced.

For the hydraulic hoses other than the ones to be replaced periodically, inspect them for the following points. If found unusual, tighten them up, replace them.

When replacing the hydraulic hoses, change their O rings and sealings with new ones.

For replacement of the important parts, contact your KUBOTA dealer.

- At the following periodic inspections, check the fuel hoses and hydraulic hoses as well.

Inspection Interval	Check points
Daily Checks	Oil leak at fuel and hydraulic hose connections and points
Every month	Oil leak at fuel and hydraulic hose connections and points Damages at fuel and hydraulic hose (cracks, chafing)
Every year	Oil leak at fuel and hydraulic hose connections and points Interference, deformation, degradation, twist and other damages (cracks, chafing) of fuel and hydraulic hoses

**List of important component parts**

No.	Component parts	Period
1	Fuel hose	Every 2 years or 4000 hours
2	Hydraulic hose	
3	Radiator hose	
4	Closed breather related rubber piping	
5	DPF differential pressure sensor rubber piping (Front and Back)	
6	Suction pipe downstream the AFS (Air Flow Sensor)	
7	Boost sensor pressure rubber piping	
8	Intake air line	

To prevent serious damage to the hydraulic system, use only a KUBOTA genuine hydraulic hose.

# RECOMMENDED OILS

**IMPORTANT :**

1. Before delivery the hydraulic oil used was Idemitsu Daphne Super Hydro 46ST.
2. Use engine oil API service classification CJ-4.
3. Use SAE 90 (API, GL-4, GL-5) as drive unit oil for all seasons.

	Application	Viscosity	KTC recommends	Shell	ExxonMobil
Gear oil	All-weather gear oil	SAE 90	Excavator Gear Oil 90 Part Number 70000-68700 (1 Quart)	Shell Spirex HD80W-90	Mobilube HD Plus 80W-90
Hydraulic oil			Kubota Hydraulic Fluid 46HD		
Grease				Shell Alvania EP2	Mobilux EP2
Fuel				Diesel Fuel No.2-D S15	
Fuel under -5°C (23°F)				Diesel Fuel No.1-D S15	

	Application	Viscosity	KCL recommends	Shell	Esso
Gear oil	All-weather gear oil	SAE 90		Shell Spirex HD75W-90	Mobilube HD80W-90
Hydraulic oil			ExxonMobil Mobil DTE 10 Excel 46 or equivalent oil		
Grease				Shell Alvania EP2	Mobilux EP2
Fuel				Diesel Fuel No.2-D S15	
Fuel under -5°C (23°F)				Diesel Fuel No.1-D S15	

**NOTE :**◆ **Engine Oil:**

- Oil used in the engine should have an American Petroleum Institute (API) service classification and Proper SAE Engine Oil according to the ambient temperatures.

Above 25 °C (77 °F)	SAE 30 or SAE 10W-30, SAE 15W-40
0 °C to 25 °C (32 °F to 77 °F)	SAE 20 or SAE 10W-30, SAE 15W-40
Below 0 °C (32 °F)	SAE 10W or SAE 10W-30, SAE 15W-40

- Refer to the following table for the suitable API classification engine oil and the fuel.

Fuel used	Engine oil classification (API classification)
	Oil class of engines except external DPF
Ultra Low Sulfur Fuel [<0.0015% (15 ppm)]	<b>CJ-4</b>

◆ **Fuel:**

- Use the ultra low sulfur diesel fuel only [below 0.0015 % (15 ppm)] for these engines.
- Cetane number of 45 minimum. Cetane number greater than 50 is preferred, especially for temperatures below -20 °C (-4 °F) or elevations above 1500 m (5000 ft).
- Diesel fuels specified to EN 590 or ASTM D975 are recommended.
- No. 2-D is a distillate fuel of lower volatility for engines in industrial and heavy mobile service. (SAE J313 JUN87)
- Indicated capacities of water and oil are manufacture's estimate.

**IMPORTANT :**

- If you use different fuel or engine oil, the cleaning efficiency of the DPF (3000 hours) will be reduced and the DPF longevity will be shorter than expected.
- Filters must trap fuel and lubricant sulfate additives (Zn, Pb, Na, K, Ca, Mg, Cu, Ba, P, etc.) as ash during combustion. Fuel must be controlled carefully to prevent the additives being mixed into fuel such as fuel tank anti-oxidants, water remover, anti-freeze and so on.

# APPENDICES

## MAIN DIMENSIONS

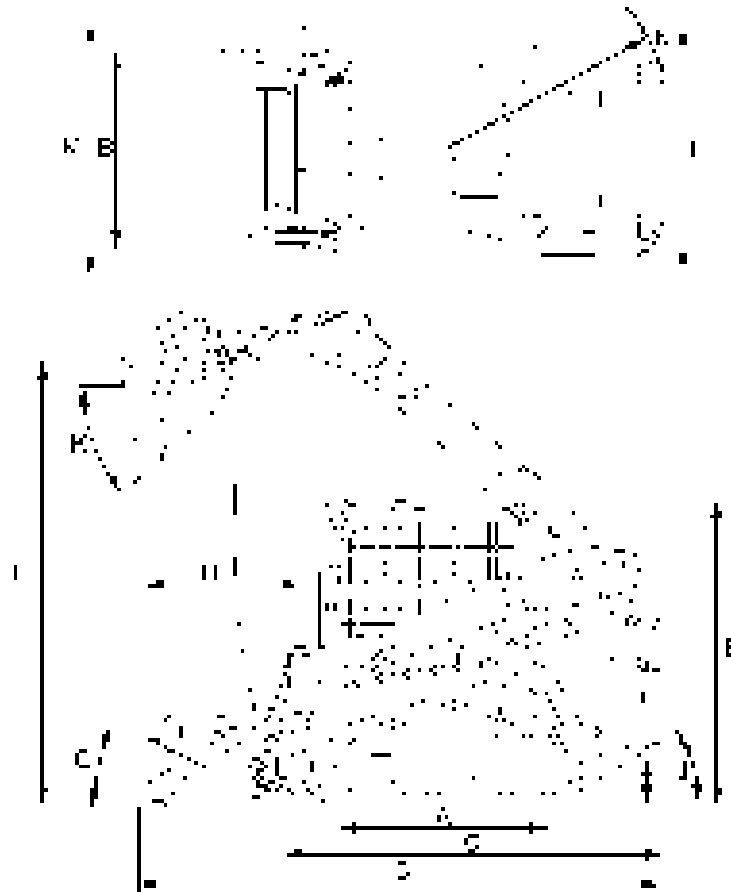

TABLE 1

Model		SVL75-2	
A	Length of track on ground	mm (in.)	1436 (56.5)
B	Track gauge	mm (in.)	1355 (53.3)
C	Length w/o bucket	mm (in.)	2768 (109)
D	Length w/bucket on ground	mm (in.)	3576 (140.8)
E	Height to top of cab	mm (in.)	2083 (82)
F	Bucket hinge pin height at max. lift	mm (in.)	3025 (119.1)
G	Rollback angle at carry position	degree	27
H	Reach at max. lift and dump	mm (in.)	1060 (41.7)
I	Ground clearance	mm (in.)	296 (11.7)
J	Departure angle	degree	31.5
K	Max. dump angle	degree	40
L	Vehicle width	mm (in.)	1675 (65.9)
M	Width with bucket	mm (in.)	1727 (68)
N	Turning radius from center-machine rear	mm (in.)	2720 (107.1)

### NOTE :

- Above dimensions are based on the machine with KUBOTA standard bucket.
- Above dimensions are based on the machine with KUBOTA standard rubber track.
- Specifications subject to change without notice.